

# PROPOSED 3-STORY MIXED-USE BUILDING

## OWNER - DR. OMOBOLA OJI

29 PEARL STREET, NORTH PLAINFIELD, NEW JERSEY  
ISSUE FOR APPROVAL - 01/15/2021

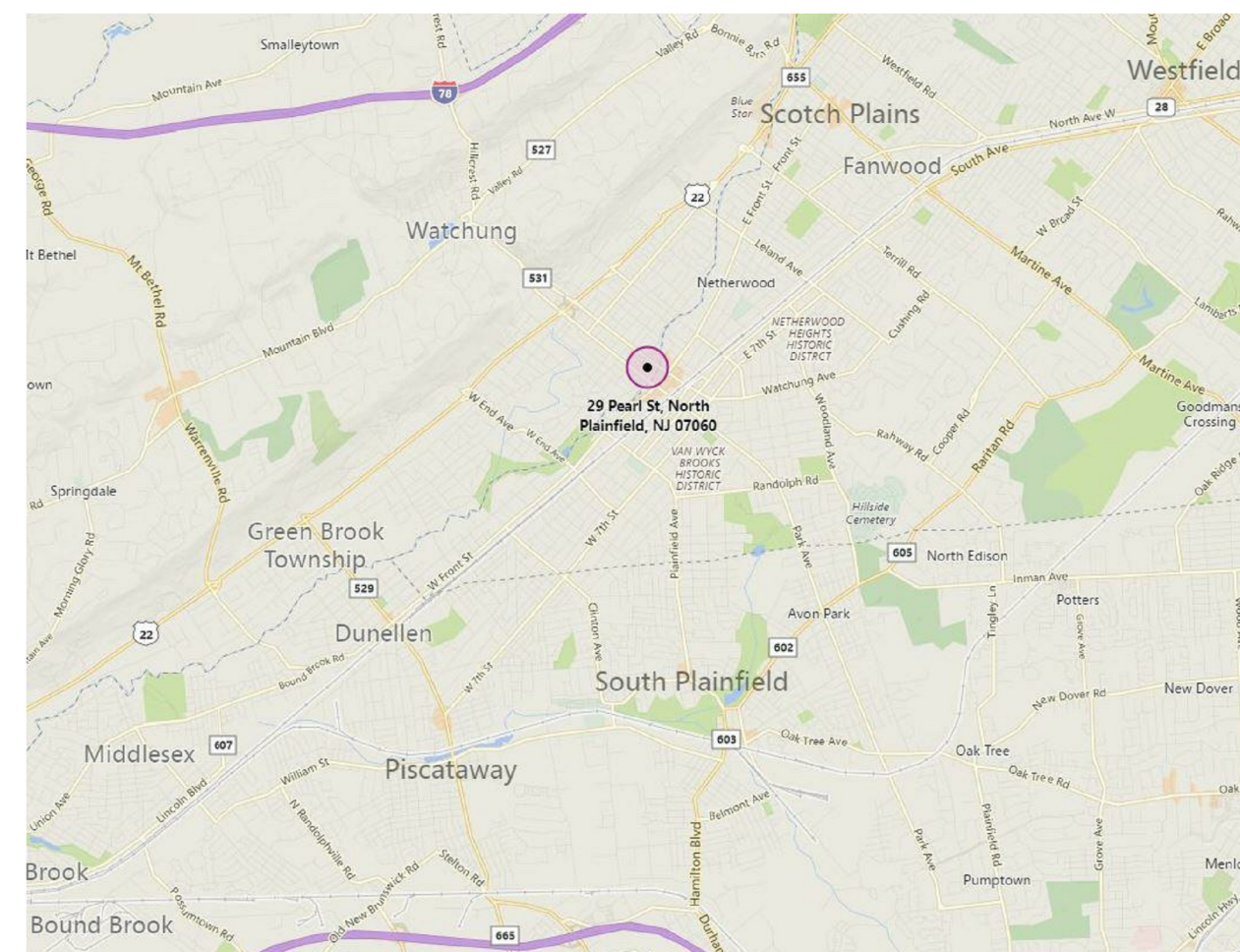

VICINITY MAP

PERSPECTIVE VIEW FROM ROAD

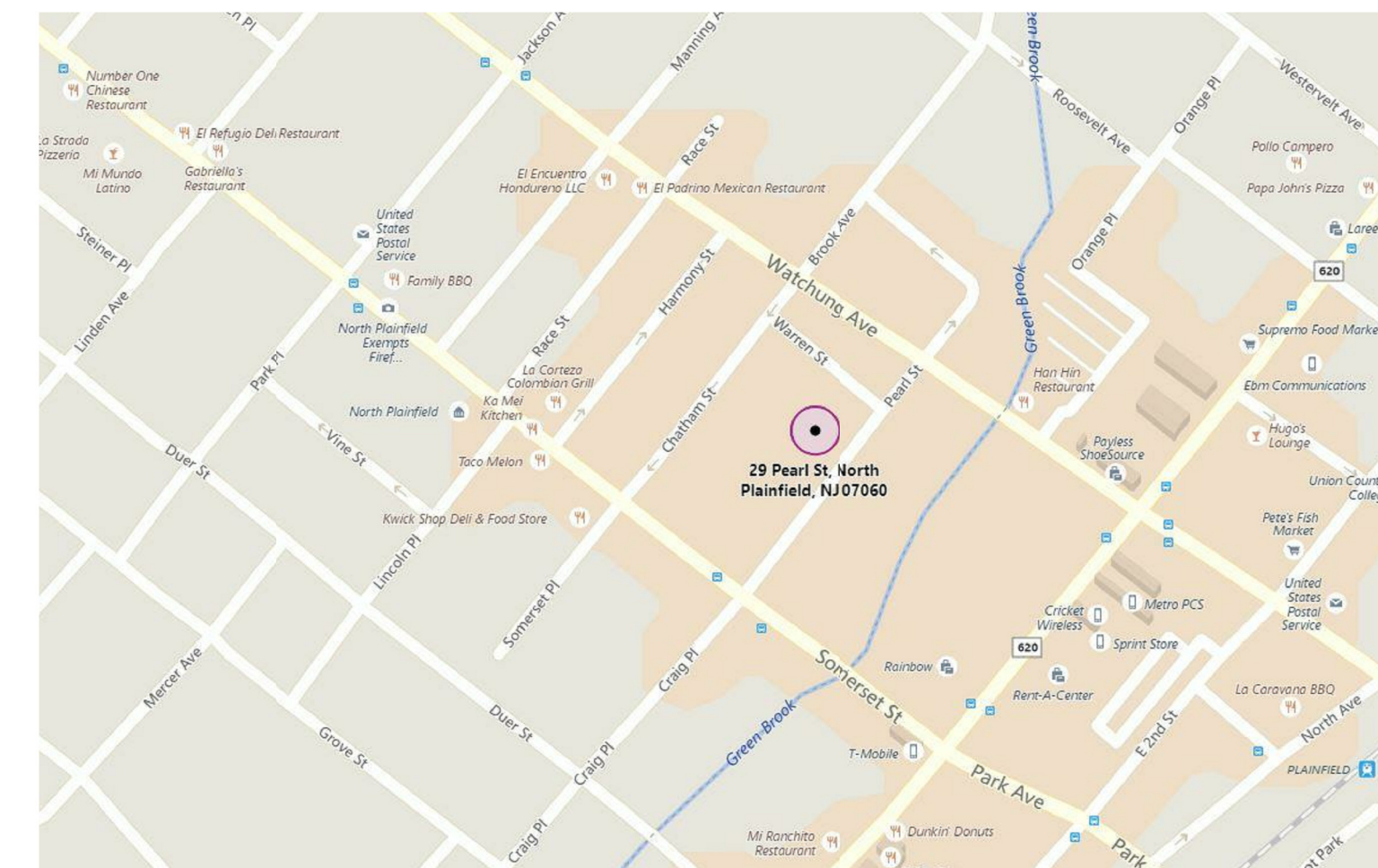

LOCATION MAP

REV / ISSUE	DATE	DESCRIPTION
01/15/21		ISSUE FOR APPROVAL

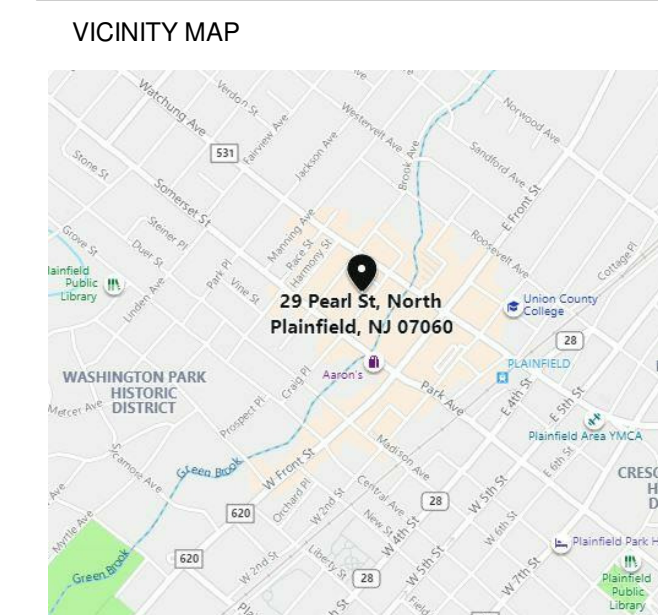

**Studio b llc**  
144 FRESH PONDS ROAD  
EAST BRUNSWICK, NJ 08816  
732.713.2627

ALL DIMENSIONS MUST BE VERIFIED BY THE CONTRACTOR. NOTIFY STUDIO B ARCHITECTURE OF ANY CONFLICTS, ERRORS, OMISSIONS OR DISCREPANCIES IN THE CONTRACT DRAWINGS OR SPECIFICATIONS BEFORE PROCEEDING WITH CONSTRUCTION.  
ALL DIMENSIONS SHALL BE AS NOTED IN WORDS OR NUMBERS ON THE CONTRACT DRAWINGS. DO NOT SCALE THE DRAWINGS TO DETERMINE DIMENSIONS.  
THESE CONTRACT DRAWINGS CONTAIN DATA INTENDED SPECIFICALLY FOR THE NOTED PROJECT AND CLIENT. THEY ARE NOT INTENDED FOR USE ON OTHER PROJECTS.  
THE COPYING AND/OR REPRODUCTION OF THIS DOCUMENT OR ANY PORTION THEREOF WITHOUT THE WRITTEN PERMISSION OF STUDIO B, PC, IS PROHIBITED.  
UNLESS THESE DRAWINGS ARE SPECIFICALLY DESIGNATED AS "CONSTRUCTION ISSUE", THESE DRAWINGS SHALL NOT BE USED FOR CONSTRUCTION OR IMPROVEMENTS IDENTIFIED HEREIN. CONTRACTORS SHALL NOTIFY THE DESIGN ENGINEER TO OBTAIN CONSTRUCTION DOCUMENTS.  
COPYRIGHT 2020 STUDIO B ARCHITECTURE - ALL RIGHTS RESERVED.

**Robert Blakeman**  
Registered Architect - New Jersey  
Licence No. 07029

SIGNATURE DATE 01/15/21

CLIENT  
**DR. OMOBOLA OJI**

PROJECT  
**PROPOSED  
3-STORY  
MIXED-USE  
BUILDING**  
LOT 20, BLOCK 85, 29 PEARL STREET, NORTH  
PLAINFIELD, NEW JERSEY

SHEET NAME  
**COVER SHEET**

JOB NO.: 2020.005  
DATE: 11/22/20  
DRAWN: ARCH  
CHECK: EY / RB  
SCALE:

SHEET NO.

**GN1.0**

## GENERAL NOTES

- THE WORK SHALL CONFORM TO THE APPLICABLE BUILDING CODE AND OTHER ORDINANCES, CODES AND REGULATIONS LISTED IN THE SPECIFICATIONS OR ON THE DRAWINGS, AND REQUIRED BY LOCAL BUILDING AUTHORITIES. THE GOVERNING CODES, RULES AND REGULATIONS ARE COLLECTIVELY REFERRED TO AS 'THE CODE'. THE CONTRACTOR SHALL REPORT ANY INCONSISTENCIES, CONFLICTS OR OMISSIONS DISCOVERED TO THE ARCHITECT FOR INTERPRETATION PRIOR TO PERFORMING THE WORK.
- THE GENERAL CONTRACTOR SHALL BE RESPONSIBLE FOR THE SUB-CONTRACTORS' RECEIPT OF COMPLETE SETS OF THESE DOCUMENTS, AS WELL AS ALL FUTURE ADDENDA, BULLETINS, FIELD DIRECTIVES AND CHANGE ORDERS.
- THE CONTRACTOR SHALL COORDINATE WITH THE BUILDING MANAGEMENT THE STORAGE OF MATERIALS AND SHALL PROVIDE PROTECTION AS NECESSARY TO PREVENT VANDALISM AND LOSS OF MATERIALS BY THEFT OR DAMAGE SUSTAINED DUE TO EXPOSURE TO INAPPROPRIATE ENVIRONMENTAL CONDITIONS AND WILL REPAIR & REPLACE DAMAGE OR LOSSES AT THE CONTRACTORS' EXPENSE WITHOUT CHARGE TO THE OWNER.
- THE CONTRACTOR SHALL ASSUME SOLE AND COMPLETE RESPONSIBILITY FOR JOB SITE CONDITIONS DURING THE COURSE OF CONSTRUCTION OF THIS PROJECT INCLUDING SAFETY OF ALL PERSONS AND PROPERTY. THIS REQUIREMENT SHALL APPLY CONTINUOUSLY AND NOT BE LIMITED TO NORMAL WORKING HOURS. THE CONTRACTOR SHALL PROVIDE PUBLIC PROTECTION, AS NECESSARY AND REQUIRED BY GOVERNING AGENCIES HAVING JURISDICTION, UNTIL CLIENT ACCEPTANCE OF THE PREMISES.
- THE GENERAL CONTRACTOR IS SOLELY RESPONSIBLE FOR THE PROVISION AND MAINTENANCE OF ALL BRACING, SHORING, ENCLOSURES, BARRIERS OR SCAFFOLDING REQUIRED TO PROVIDE A SAFE WORKING ENVIRONMENT AS DICTATED BY SITE CONDITIONS AND THE PROGRESS OF WORK.
- THE CONTRACTOR SHALL INDEMNIFY AND SAVE HARMLESS THE LANDLORD, THE TENANT, AND ARCHITECT AGAINST ANY AND ALL CLAIMS AND DEMANDS FOR THE DAMAGE TO THE PROPERTY OF ANY PERSON, FIRM OR INDIVIDUAL OR FOR PERSONAL INJURIES (INCLUDING DEATH) ARISING OUT OF, OR SUFFERED WHILE ENGAGED IN, OR CAUSED, IN WHOLE OR PART, BY THE EXECUTION OF THE WORK; THE CONTRACTOR SHALL HELL AND TRULY DEFEND THE LANDLORD, TENANT AND ARCHITECT SHALL PAY ALL MONIES AWARDED FOR SUCH DAMAGES OR INJURIES (INCLUDING DEATH), ALL COSTS INCLUDING ATTORNEY'S FEES SUSTAINED, AND SHALL OBTAIN A FULL ACQUITTANCE AND RELEASE IN FAVOR OF THE LANDLORD, TENANT AND ARCHITECT, UNLESS SUCH LIABILITY RESULTS SOLELY FROM THE NEGLIGENCE OF THE LANDLORD, TENANT, ARCHITECT, ITS AGENTS OR EMPLOYEES.
- THE ARCHITECT SHALL NOT BE HELD RESPONSIBLE FOR THE PERFORMANCE OF ANY WORK, NOR FOR THE MEANS AND METHODS OF CONSTRUCTION CHOSEN BY THE CONTRACTOR OR ANY SUB-CONTRACTORS, NOR SHALL THE ARCHITECT GUARANTEE THE PERFORMANCE OF THEIR CONTRACTS.
- THE CONTRACTOR SHALL PERFORM DAILY CLEANING OF THE JOB SITE DURING THE CONSTRUCTION PERIOD AND SHALL PROTECT FINISHED WORK FROM DAMAGE. IMMEDIATELY PRIOR TO TENANT OCCUPANCY, THE CONTRACTOR SHALL PERFORM FINAL CLEANING OF THE WORK AREA INCLUDING BUT NOT LIMITED TO, NETTING OF FURNITURE AND CASEWORK, TILES, WASHING AND MOWING OF VCT FLOORING AND THE VACUUMING OF CARPET. ALL CLEANING SHALL BE IN ACCORDANCE WITH MANUFACTURERS' RECOMMENDATIONS.
- THE CONTRACTOR IS RESPONSIBLE FOR COORDINATING THE WORK OF ALL SUB-CONTRACTORS AND SHALL PERFORM SUCH MISCELLANEOUS WORK AS MAY BE NECESSARY FOR THEM TO COMPLETE THEIR WORK. IT IS EXPECTED THAT THE CONTRACTOR SHALL ALSO CLOSELY COORDINATE THE WORK WITH THAT OF ALL OTHER VENDORS RETAINED BY THE CLIENT TO ASSURE THAT ALL SCHEDULES ARE MET AND THAT WORK PROCEEDS WITHOUT DELAY.
- BIDDERS, BEFORE SUBMITTING PROPOSALS, SHALL VISIT AND CAREFULLY EXAMINE THE AREA AFFECTED BY THE WORK TO FAMILIARIZE THEMSELVES WITH THE EXISTING CONDITIONS AND THE DIFFICULTIES THAT WILL AFFECT THE EXECUTION OF THE WORK. SUBMISSION OF A PROPOSAL WILL BE CONSTRUED AS EVIDENCE THAT SUCH AN EXAMINATION HAS BEEN MADE, AND LATER CLAIMS WILL NOT BE RECOGNIZED FOR EXTRA LABOR, EQUIPMENT, OR MATERIALS, REQUIRED BECAUSE OF DIFFICULTIES ENCOUNTERED WHICH COULD HAVE BEEN REASONABLE FORESEEN HAD SUCH AN EXAMINATION BEEN MADE. THE GENERAL CONTRACTOR SHALL VERIFY ALL CONDITIONS AND DIMENSIONS ON THE JOB SITE AND REPORT ANY AND ALL DISCREPANCIES AND/OR UNUSUAL CONDITIONS TO THE ARCHITECT PRIOR TO FINALIZING BIDS OR COMMENCEMENT OF ANY CONSTRUCTION.
- THE GENERAL CONTRACTOR SHALL MAKE KNOWN ANY AND LIMITATION, EXCLUSIONS, OR MODIFICATIONS TO THE PROJECT DURING THE BID SELECTIONS PERIOD. ANY AND ALL LIMITATIONS, EXCLUSIONS, OR MODIFICATIONS NOT ITEMIZED IN THE BID PROPOSAL DOCUMENTS ARE PRESUMED 'INCLUDED', IN WHICH CASE NO ADDITIONAL MONIES WILL BE ALLOCATED FOR THIS WORK.
- ALL COSTS FOR INSPECTIONS AND/OR TESTS SHALL BE THE RESPONSIBILITY OF THE CONTRACTOR, U.N.O.
- THE CONTRACTOR SHALL MAKE ALL ARRANGEMENTS, MAINTAIN AND PAY ALL COSTS FOR TEMPORARY WATER, PLUMBING, POWER, LIGHTING HEATING OR VENTILATION REQUIRED TO PROPERLY CONDUCT THE WORK.
- DO NOT SCALE THESE DRAWINGS; WRITTEN DIMENSIONS SHALL GOVERN SHOULD ANY DIMENSIONAL DISCREPANCIES BE ENCOUNTERED. CLARIFICATIONS SHALL BE OBTAINED FROM THE OFFICE OF THE ARCHITECT.
- LARGE SCALE DETAILS SHALL GOVERN OVER SMALLER SCALE PLANS AND ELEVATIONS.
- INSTALL ALL EQUIPMENT AND MATERIALS PER MANUFACTURERS' RECOMMENDATIONS. ANY DIFFICULTIES ARE TO BE REPORTED TO THE ARCHITECT IMMEDIATELY.
- THE CONTRACTOR AND SUBCONTRACTOR SHALL WARRANT ALL WORK PERFORMED BY HIM DIRECTLY FOR A MINIMUM PERIOD OF ONE (2) YEAR AS SPECIFIED IN THE CONSTRUCTION CONTRACT. ALL DEFECTS OCCURRING IN THE GUARANTEED PERIOD SHALL BE CORRECTED AT NO ADDITIONAL COST.
- THE CLIENT, ARCHITECT, CONSULTANTS AND ALL INSPECTORS FROM PERTINENT AGENCIES SHALL BE PERMITTED ACCESS TO THE JOB SITE AT ALL TIMES DURING NORMAL WORKING HOURS.
- THE CONTRACTOR SHALL PROVIDE ALL LABOR, MATERIALS, AND EQUIPMENT NECESSARY TO EXECUTE ALL WORK, EXCEPT WHERE NOTED AS NOT IN CONTRACT (N.I.C.).
- MINOR DETAILS NOT SHOWN OR SPECIFIED, BUT NECESSARY FOR PROPER CONSTRUCTION OF ANY PART OF THE WORK, SHALL BE INCLUDED AS IF THEY WERE INDICATED IN THE DRAWINGS, UNLESS OTHERWISE AGREED UPON.
- WHERE THE CONTRACT, CONSTRUCTION NOTES OR DRAWINGS CALL FOR ANY WORK OF A MORE STRINGENT NATURE THAN THAT REQUIRED BY THE BUILDING CODE, OR ANY OTHER ENTITY HAVING JURISDICTION OVER THE WORK, THE WORK OF THE MORE STRINGENT NATURE CALLED SHALL BE FURNISHED IN ALL CASES.
- DETAILS ARE INTENDED TO SHOW THE INTENT OF THE DESIGN. MINOR MODIFICATIONS MAY BE REQUIRED TO SUIT FIELD CONDITIONS. REQUIRED MODIFICATIONS SHALL BE INCLUDED AS PART OF THE WORK.
- ALL WORK SHALL BE EXECUTED IN A WORKMANLIKE MANNER BY MECHANICS AND TRADEPERSONS SKILLED IN THEIR RESPECTIVE TRADES AND IN ACCORDANCE WITH THE BEST TRADE PRACTICES.
- SUBSTITUTION OF ALL EQUALS SHALL BE ONLY AS APPROVED BY THE ARCHITECT. WHERE THE TERM 'OR EQUAL' IS USED THE ARCHITECT SHALL BE THE SOLE JUDGE OF EQUALITY BASED UPON THE INFORMATION FURNISHED BY THE CONTRACTOR. SUBSTITUTIONS MUST BE ACCEPTED IN WRITING BEFORE THEY MAY BE USED.
- THE CONTRACTOR SHALL PREPARE SUBMITTALS FOR REVIEW BY THE ARCHITECT, FOR ALL MATERIALS AND EQUIPMENT SPECIFIED. IF THE CONTRACTOR, OR OWNER, OR THE OWNER'S REPRESENTATIVE SUBSTITUTES A MATERIAL, METHOD ATTACHMENT, REVISED A CONSTRUCTION DETAIL, OR IN ANY WAY ALTERS THE WORK SUCH THAT IT NO LONGER CONFORMS TO THESE DOCUMENTS, WITHOUT THE WRITTEN ACCEPTANCE OF THE ARCHITECT, SUCH ACTION WILL RELIEVE THE ARCHITECT OF ANY RESPONSIBILITY OR LIABILITY INCLUDING, BUT NOT LIMITED TO, AESTHETIC CONSEQUENCES, SUBSEQUENT FAILURES AND PERSONAL OR PERTY DAMAGE ATTRIBUTABLE TO THIS CHANGE. REVIEW OF A SPECIFIC ITEM SHALL NOT INCLUDE REVIEW OF AN ASSEMBLY OF WHICH THE ITEM IS A COMPONENT.
- SUBMITTALS THAT CONTAIN EXCESSIVE ERRORS OR ARE INCOMPLETE OR INADEQUATE MAY BE RETURNED WITHOUT ACTION. COSTS INCURRED FOR THE RESULTANT DELAYS WILL BE THE RESPONSIBILITY OF THE CONTRACTOR.
- REVIEW OF SUBMITTALS SHALL NOT RELIEVE THE CONTRACTOR OF OBLIGATIONS OR RESPONSIBILITIES FOR DEVIATIONS FROM THE REQUIREMENTS OF THESE CONTRACT DOCUMENTS, UNLESS THE ARCHITECT IS NOTIFIED AND SPECIFICALLY APPROVES OF, THE DEVIATIONS AT THE TIME OF SUBMISSION.
- REVIEW OF SUBMITTALS SHALL NOT RELIEVE THE CONTRACTOR'S OBLIGATION FOR COORDINATION NOR HAVE RESPONSIBILITY FOR ERRORS AND OMISSIONS IN THE SUBMITTALS, INCLUDING 'FIELD MEASURE'.
- THE PRESENCE OF A REPRESENTATIVE OF THE ARCHITECT ON THE JOB SITE DOES NOT IMPLY CONCURRENCE WITH OR THE APPROVAL OF ANY WORK. THE CONTRACTOR SHALL CALL TO THE ATTENTION OF THE ARCHITECT, IN WRITING, ALL SPECIFIC ITEMS FOR WHICH ARCHITECT'S REVIEW IS REQUIRED.
- UPON SUBSTANTIAL COMPLETION OF WORK THE CONTRACTOR SHALL PREPARE A 'PUNCHLIST' OF CORRECTIONS AND UNSATISFACTORY AND/OR INCOMPLETE WORK FOR REVIEW BY THE ARCHITECT.
- THE CONTRACTOR SHALL MAINTAIN AT THE SITE, ONE RECORD OR COPY OF ALL DRAWINGS, PERMITS, SUBMITTALS AND SAMPLES ON WHICH TO RECORD ALL CHANGES DURING CONSTRUCTION, ACCESS TO THESE SHALL BE PROVIDED FOR THE USE OF ALL TRADES, CLIENT REPRESENTATIVES AND THE ARCHITECT, DURING ALL PHASES OF CONSTRUCTION.
- PRIOR TO THE COMPLETION OF THE WORK, THE CONTRACTOR SHALL ASSEMBLE AND FURNISH THE CLIENT A COMPLETE SET OF MANUFACTURERS' CATALOGS, OPERATING INSTRUCTIONS, START-UP CHECK LIST, MAINTENANCE INSTRUCTIONS AND SIMILAR DATA, AS WELL AS GUARANTEE(S) FOR ALL EQUIPMENT AND OPERABLE DEVICES FURNISHED OR INSTALLED BY THE CONTRACTOR UNDER THIS CONTRACT, AND SHALL ORIENT AND INSTRUCT THE PERSONNEL DESIGNATED BY THE CLIENT IN THE OPERATION OF ALL SUCH EQUIPMENT.

## DRAWING LIST

ARCHITECTURAL DRAWING LIST		
Sheet Number	Sheet Name	01/15/21 ISSUE FOR APPROVAL
GN1.0	COVER SHEET	X
GN1.1	GENERAL NOTES, ABBREVIATIONS & DRAWING LIST	X
GN1.2	ADA DIAGRAMS	X
GN1.3	3D VIEW	X
A0.01	ARCHITECTURAL SITE PLAN	X
A1.01	FIRST FLOOR PLAN	X
A1.02	SECOND FLOOR PLAN	X
A1.03	THIRD FLOOR PLAN	X
A1.04	ROOF PLAN	X
A2.01	NORTH & SOUTH ELEVATIONS	X
A2.02	EAST & WEST ELEVATIONS	X

## ABBREVIATIONS

#	AND	DEMO	DEMOLITION	FL, FLR	FLOOR	ID	INSIDE DIAMETER	N	NORTH	REG	REGISTER	U.G.	USE GROUP
@	AT	DES	DESIGN	FLUOR	FLUORESCENT	INCL	INCLUDE, INCLUDED	NC	NOT IN CONTRACT	REN	REINFORCED	UL	UNDERWRITER'S LABORATORY
AB	ANCHOR BOLT	DET	DETAIL	FND	FOUNDATION	INFO	INFORMATION	NTS	NOT TO SCALE	REM	REMOVED	U.O.N.	UNLESS OTHERWISE NOTED
A/C	AIR CONDITIONING	DF	DRINKING FOUNTAIN	F/O	FLOOR OPENING	INSUL	INSULATE, INSULATION	NO, #	NUMBER	REQ(D)	REQUIRED	VB	VINYL BASE
ACT	AQUACULTURAL CEILING TILE	DIAS	DIAGONAL	F/O	FACE OF	INT	INTERIOR	OV	OVER-HANG	RES	RESILIENT	VCT	VINYL COMPOSITE TILE
AD	AREA DRAIN	DIAM	DIAMETER	FOB	FACE OF BLOCK	INV	INVERT	OA	OVERALL	RM	ROOM	VERT	VERTICAL
AFF	ABOVE FINISH FLOOR	DIFF	DIFFUSER	FPRF	FIREPROOF (ING)	JAN	JANITOR	OC, O/C	ON CENTER	RO	ROUGH OPENING	VTR	VENT THROUGH ROOF
ADJ	ADJUSTABLE	DIM	DIMENSION	FT	FOOT OR FEET	JAN	JANITOR	OD	OUTSIDE DIAMETER	ROV	RIGHT OF WAY	IV	WITH
ALT	ALTERNATE	DIST	DISTANCE	FTG	FOOTING	JG	JANITOR'S CLOSET	OFF	OFFICE	SAD	SADDLE	IC	WATER CLOSET
ALUM	ALUMINUM	DN	DOWN	FUT	FUTURE	JST	JOIST	OH	OVER-HANG	SAFB	SOUND ATTENUATION FIRE	NO	WOOD
APPROX	APPROXIMATELY	DR	DOOR	GA	GAGE	JT	JOINT	OPN	OPENING	OPP	OPPOSITE	NG	WIRE GLASS
ARCH	ARCHITECT	DWG	DRAWING	GALV	GALVANIZED	KD	KNOCK DOWN	OPP	OPPOSITE	SC	SCHEDULE	WN	WINDOW
BD	BOARD	E	EAST	GC	GENERAL CONTRACTOR	KO	KNOCK OUT	PART, PTN	PARTITION	SCHD	SCHEDULE	W/O	WITHOUT
BLDG	BUILDING	EA	EACH	GL	GLASS	KP	KICK PLATE	PL	PLATE	SECT	SECTION	MP	MATERPROOFING
BLK	BLOCK	EL	ELEVATION	GND	GROUND	L	LENGTH	PLAM	PLASTIC LAMINATE	SERV	SERVICE	MR	MATER REPELLENT
BLK'S	BLOCKING	ELEG	ELECTRIC (AL)	GR	GRADE	LAM	LAMINATE	PLAS	PLASTIC	SHT	SHEET	NT	NEIGHT
BM	BEAM	ELEV	ELEVATOR	GWB	GYPSPUM WALL BOARD	LAV	LAVATORY	PLYMD	PLYWOOD	SIM	SIMILAR		
BOT	BOTTOM	EMERG	EMERGENCY	GYP	GYPSPUM	LEDR	LEADER	PNL	PANEL	SPEC	SPECIFICATION		
CL	CENTERLINE	EP	ELECTRICAL PANEL	H	HIGH	LP	LOW POINT	FR	FAIR	SQ	SQUARE		
CI	CAST IRON	EQ	EQUAL	HB	HOSE BIB	LT	LIGHT	PREFAB	PREFABRICATED	ST	STREET		
CJ	CONTROL JOINT	EXST, EXG	EXISTING	HG, HCAP	HANDICAPPED	LTL	LINTEL	PROV	PROVIDE	STD	STANDARD, STD		
CLG	CEILING	EXP	EXPANSION	HR	HEADER	MAT	MATERIAL	PSF	PER SQUARE FOOT	STL	STEEL		
CLR	CLEAR	EXT	EXTERIOR	HDX	HEADWARE	MAX	MAXIMUM	PSI	PER SQUARE INCH	STRUC	STRUCTURAL		
CMU	CONCRETE MASONRY UNIT	FAST	FASTENER	HDM	HEADWARE	ME	MECHANICAL ENGINEER	P.T.	PRESSURE TREATED	SUSP CLG	SUSPENDED CEILING		
CO	CLEAN OUT	FD	FLOOR DRAIN	HST, HT	HEIGHT	ME	MECHANICAL	PT	PAINT, PAINTED	T	TREAD		
COL	COLUMN	FE	FIRE EXTINGUISHER	HM	HALLOW METAL	MEGH	MECHANICAL	QTD	QUARRY TILE	T&G	TONGUE AND GROOVE		
CONC	CONCRETE	FEG	FIRE EXTINGUISHER CABINET	HORIZ	HORIZONTAL	MFR	MANUFACTURER	FR	FIRE RESISTANT	TB	TOYEL BAR		
CONST	CONSTRUCTION	FF	FINISHED FLOOR	HP	HIGH POINT	MN	MINIMUM	R	RISER	TH	THICK		
CONT	CONTINUOUS OR CONTINUE	F&G	FIRE GLASS	HR	HOUR	MISC	MISCELLANEOUS	RAD	RADIUS	THRU	THROUGH		
CORR	CORRIDOR	FG	FIRE HOSE CABINET	HVAC	HEATING/VENTILATION/	MO	MASONRY OPENING	RCP	REINFORCED CONCRETE PIPE	TO, T/O	TOP OF		
CT	CERAMIC TILE	FIN	FINISH	HND	HARDWOOD	MTD	MOUNTED	RD	ROOF DRAIN	T&G	TOP OF		
		FIXT	FIXTURE	HNH	HOT WATER HEATER	MTL	METAL	REF	REFERENCE, REFER	TYP	TYPICAL		

REV. / ISSUE	DATE	DESCRIPTION
	01/15/21	ISSUE FOR APPROVAL

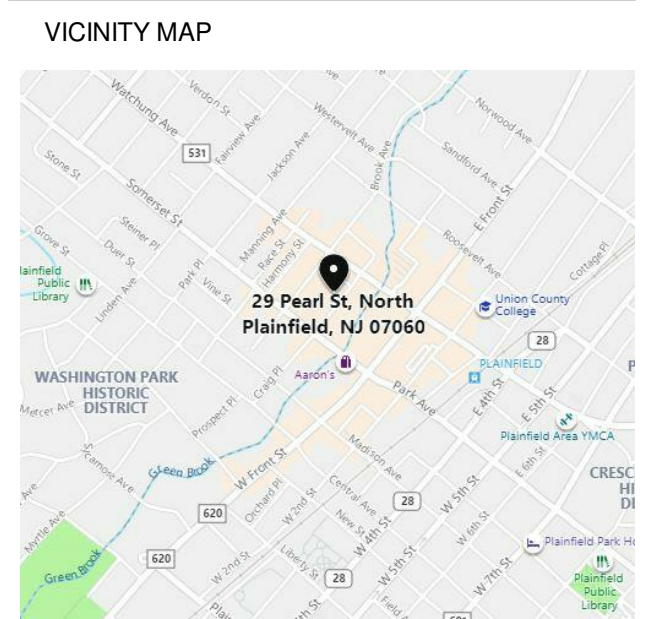

ALL DIMENSIONS MUST BE VERIFIED BY THE CONTRACTOR. NOTIFY STUDIO B ARCHITECTURE OF ANY CONFLICTS, ERRORS, AMBIGUITIES OR DISCREPANCIES IN THE CONTRACT DRAWINGS OR SPECIFICATIONS BEFORE PROCEEDING WITH CONSTRUCTION. DO NOT SCALE THE DRAWINGS TO DETERMINE DIMENSIONS.

THESE CONTRACT DRAWINGS CONTAIN DATA INTENDED SPECIFICALLY FOR THE NOTED PROJECT AND CLIENT. THEY ARE NOT INTENDED FOR USE ON OTHER PROJECTS. THE COPYING AND/OR MODIFICATION OF THIS DOCUMENT ON ANY PORTION THEREOF WITHOUT THE WRITTEN PERMISSION OF STUDIO B, P.C. IS PROHIBITED.

UNLESS THESE DRAWINGS ARE SPECIFICALLY DESIGNATED AS 'CONSTRUCTION ISSUE', THESE DRAWINGS SHALL NOT BE USED FOR CONSTRUCTION OR IMPROVEMENTS. DEPICED HEREIN. CONTRACTORS SHALL NOTIFY THE DESIGN ENGINEER TO OBTAIN CONSTRUCTION DOCUMENTS.

COPYRIGHT 2020 STUDIO B ARCHITECTURE - ALL RIGHTS RESERVED.

**Robert Blakeman**  
Registered Architect - New Jersey  
License No. 07029

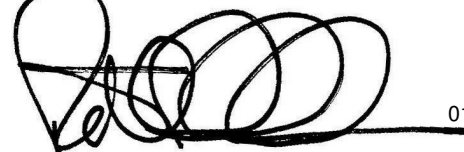
  
SIGNATURE DATE 01/15/21

CLIENT  
**DR. OMOBOLA OJI**

PROJECT  
**PROPOSED  
3-STORY  
MIXED-USE  
BUILDING**  
LOT 20, BLOCK 85, 29 PEARL STREET, NORTH  
PLAINFIELD, NEW JERSEY

SHEET NAME  
**GENERAL NOTES,  
ABBREVIATIONS &  
DRAWING LIST**

JOB NO.: 2020.005  
DATE: 11/22/20  
DRAWN: ARCH  
CHECK: EY / RB  
SCALE: As indicated

SHEET NO.

# GN1.1

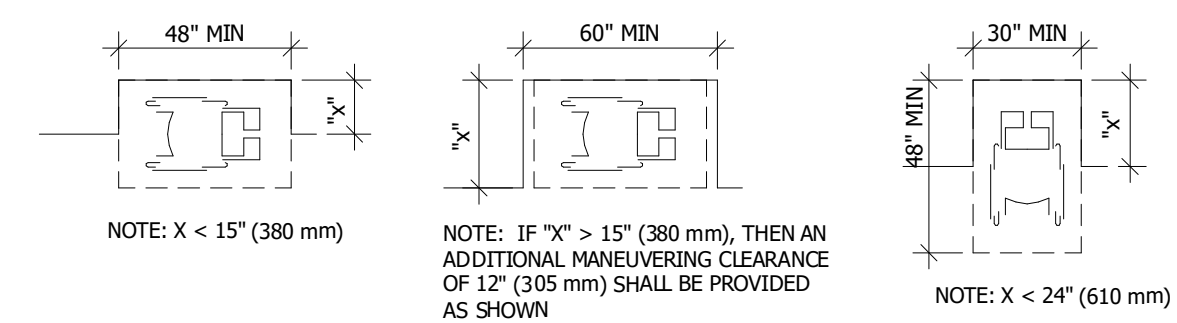

CLEAR FLOOR SPACE IN ALCOVES

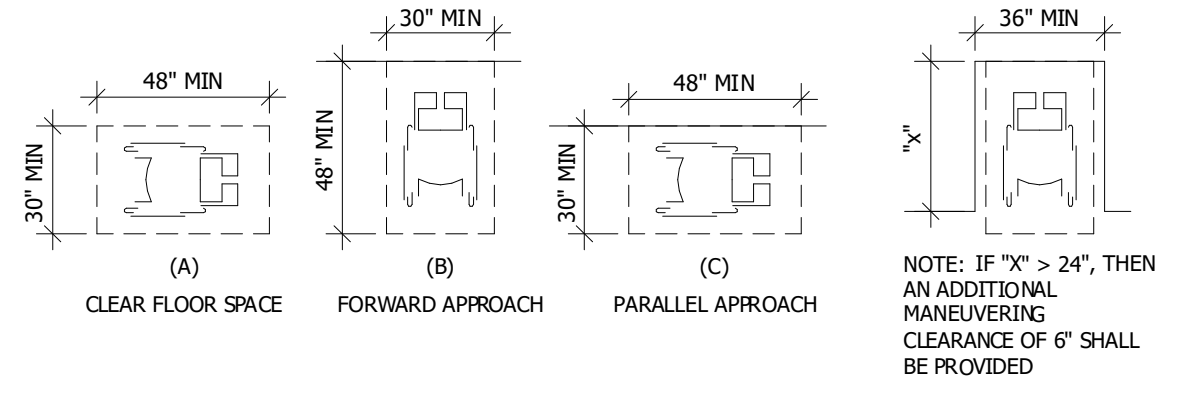

MANEUVERING CLEARANCES

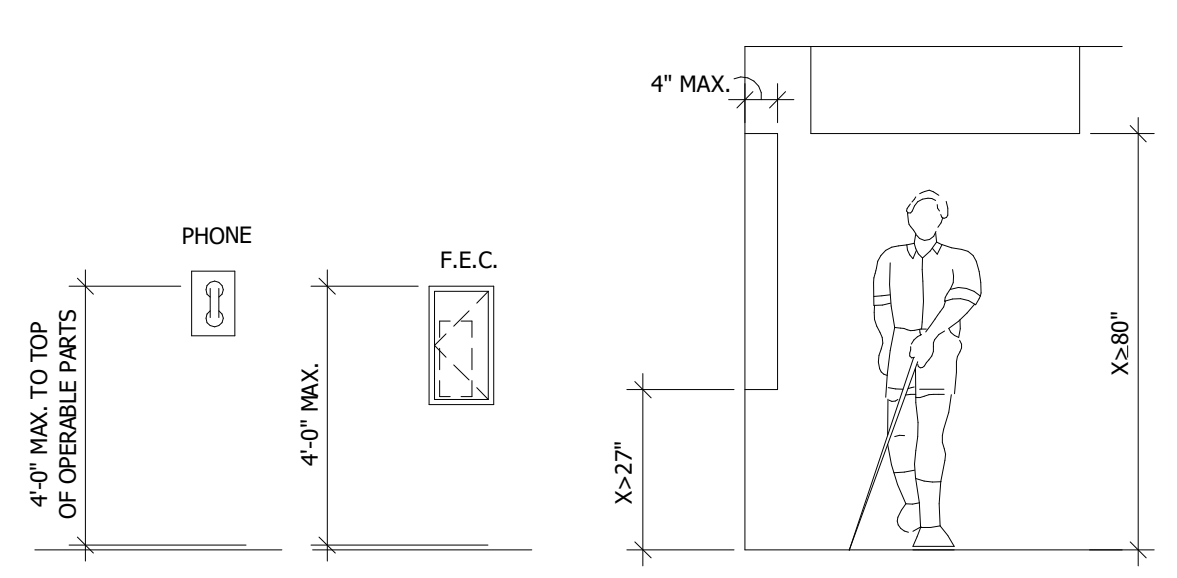
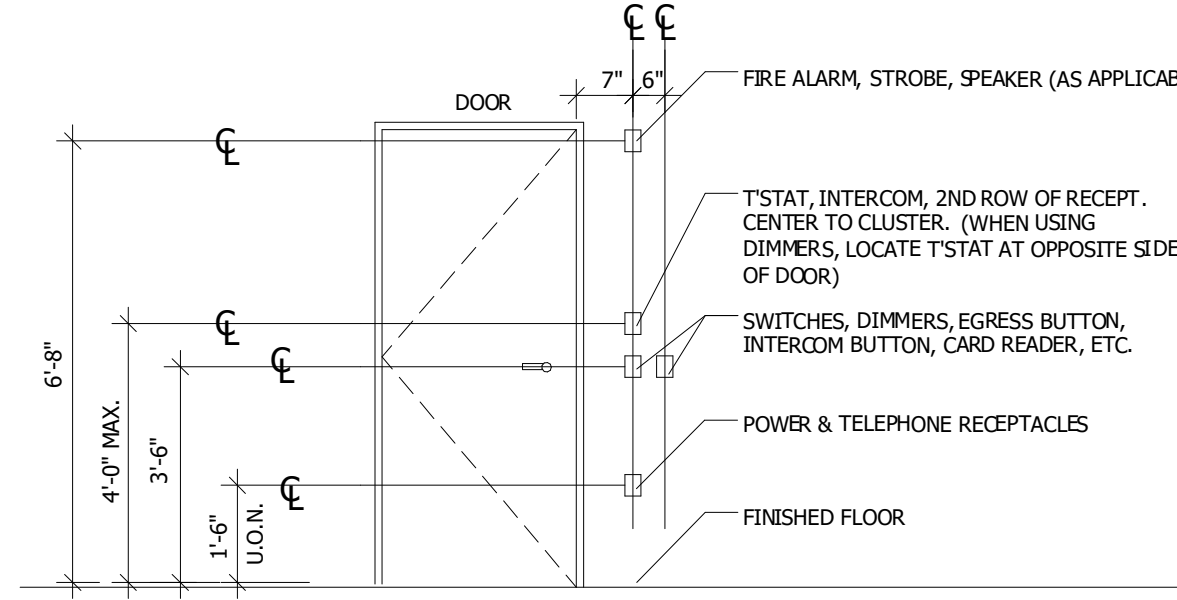

ACCESSIBLE HEIGHTS

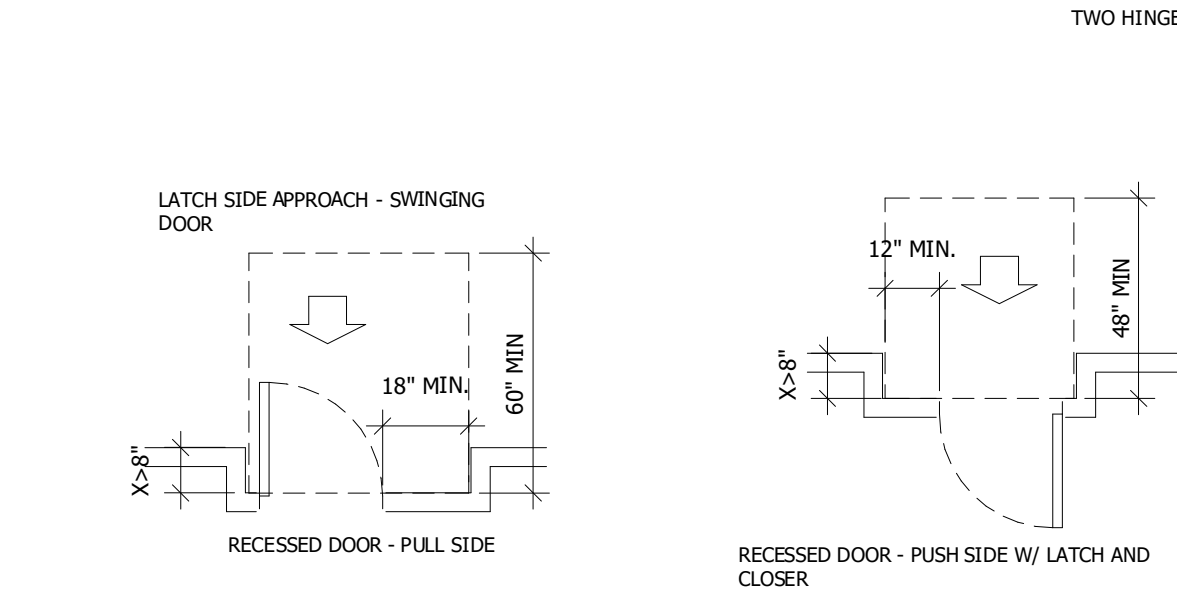
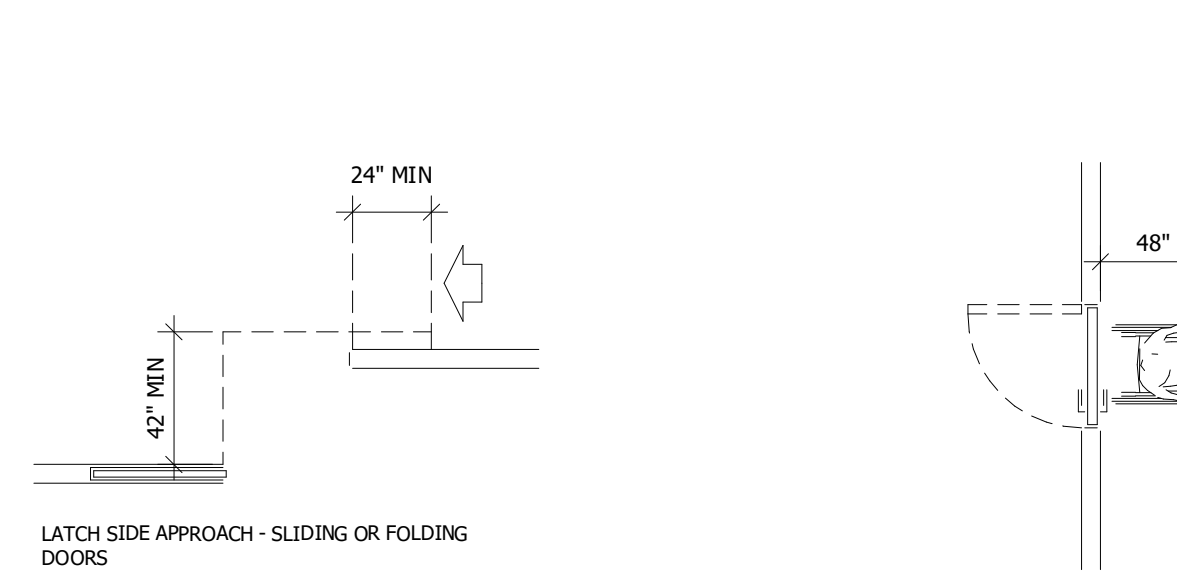
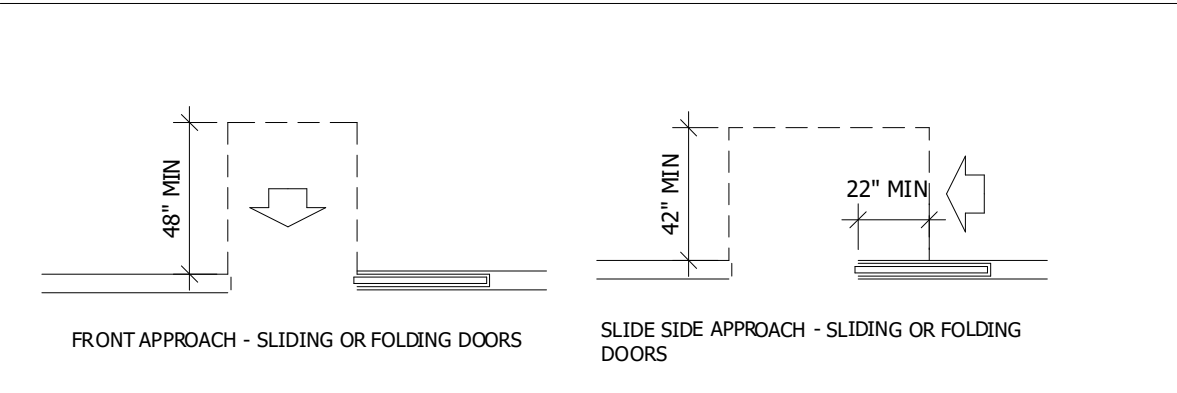

MINIMUM MANEUVERING CLEARANCES AT DOORS

**ADA DIAGRAMS**

SCALE: 1/8" = 1'-0"

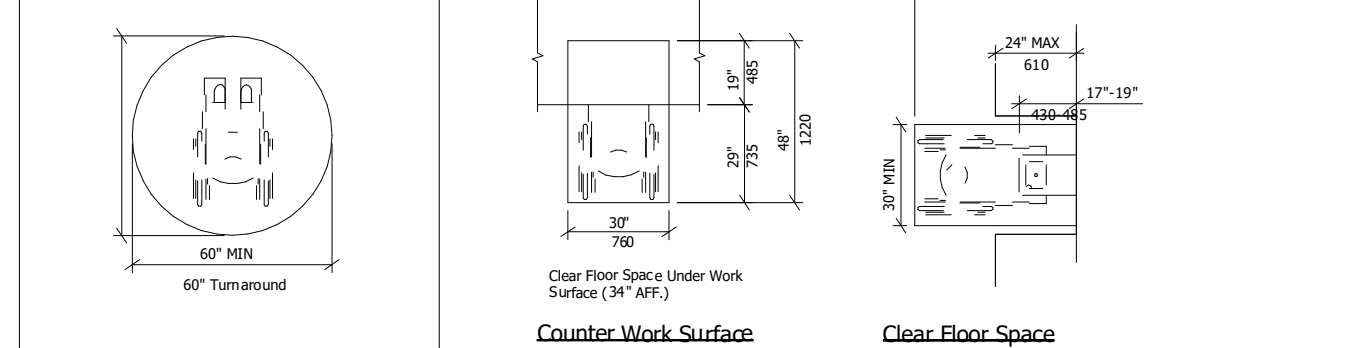

TURNING RADIUS WORK COUNTER

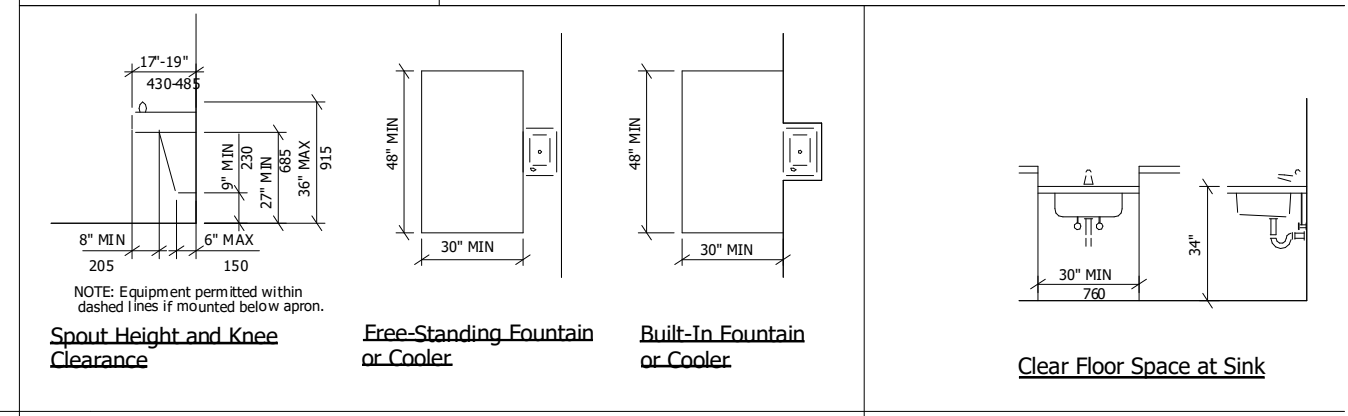

DRINKING FOUNTAIN / WATER COOLER SINK

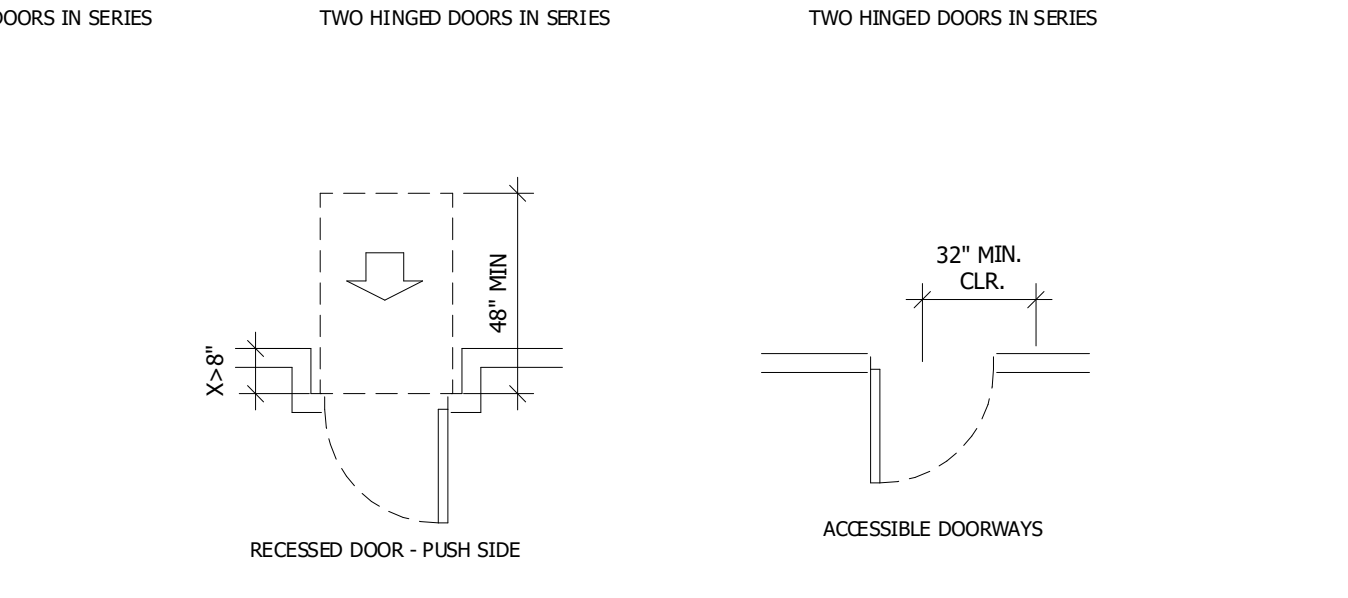
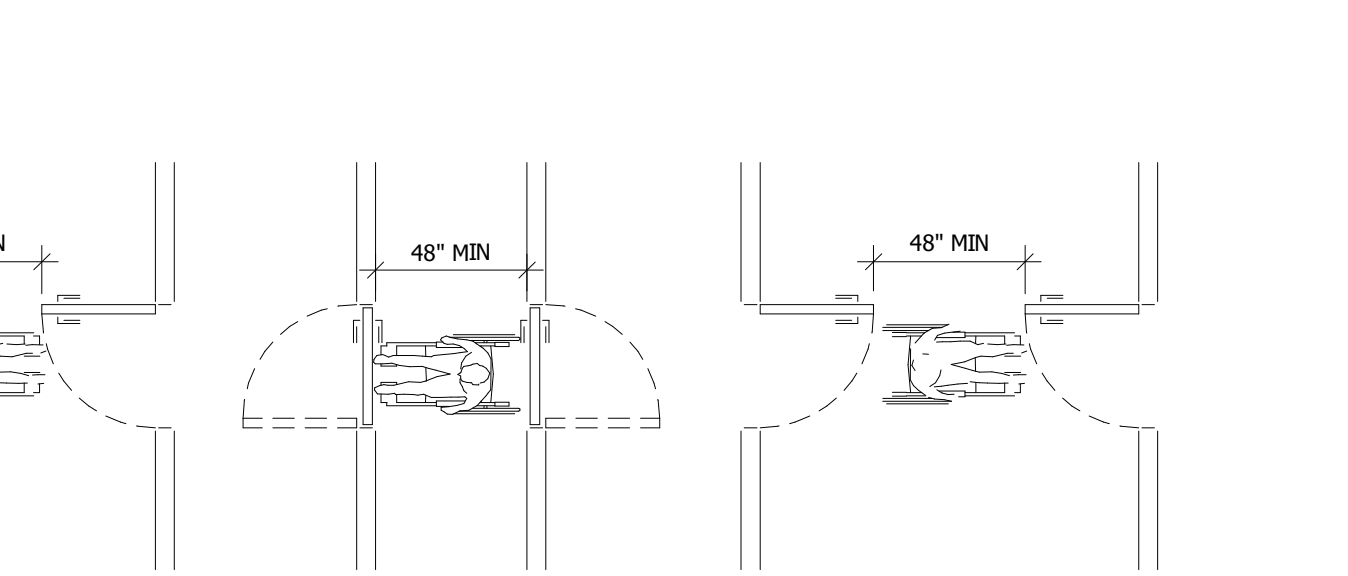
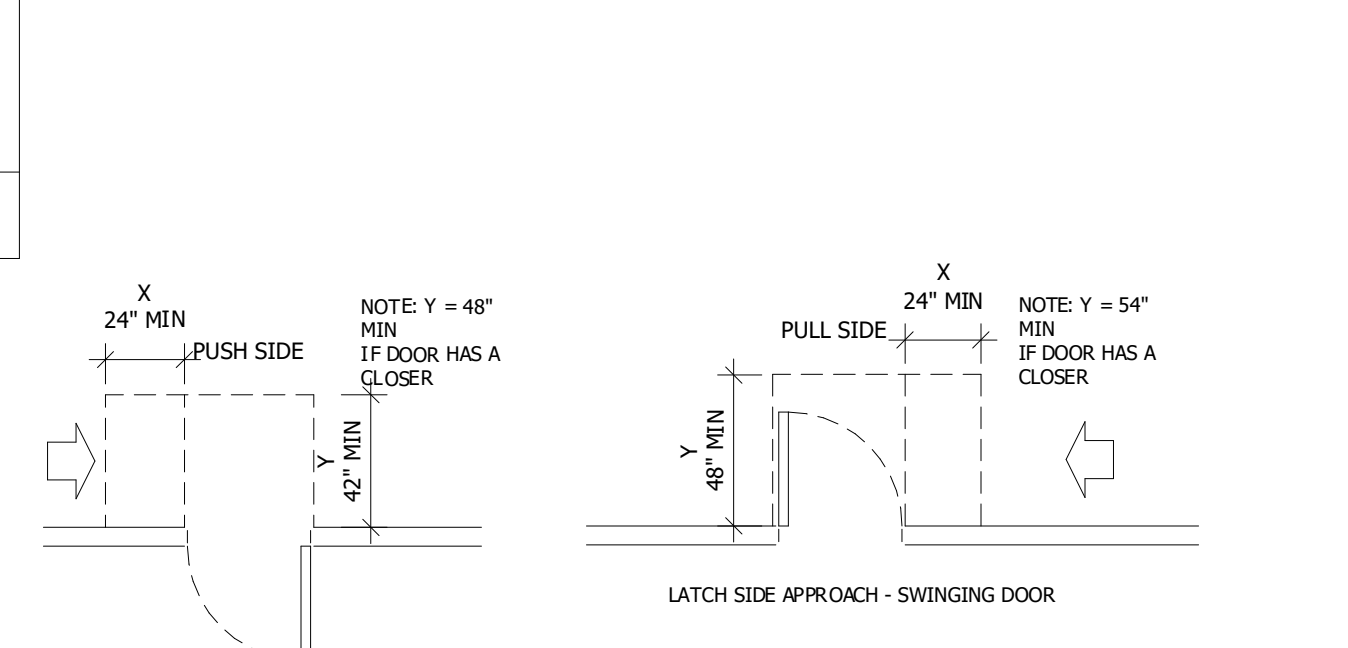
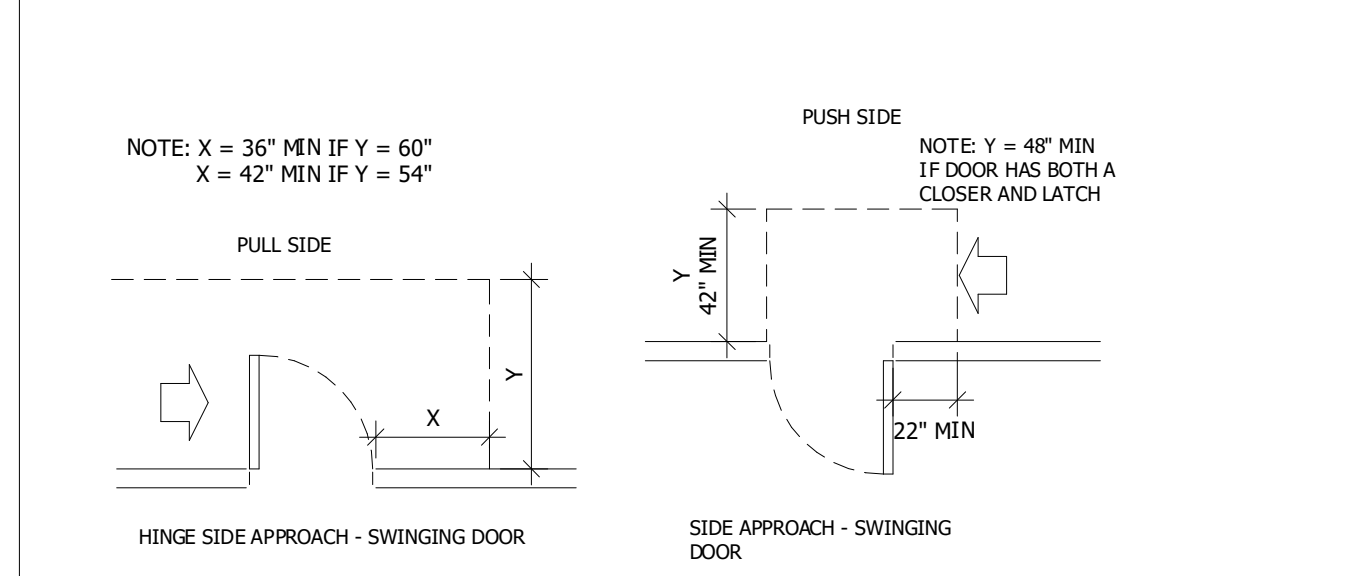
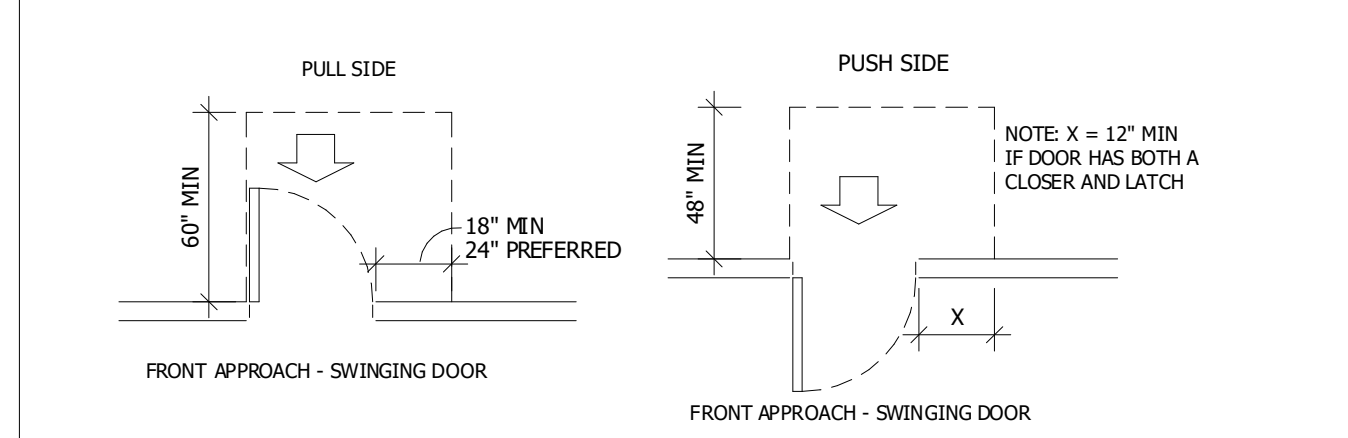

REV. / ISSUE	DATE	DESCRIPTION
01/15/21		ISSUE FOR APPROVAL

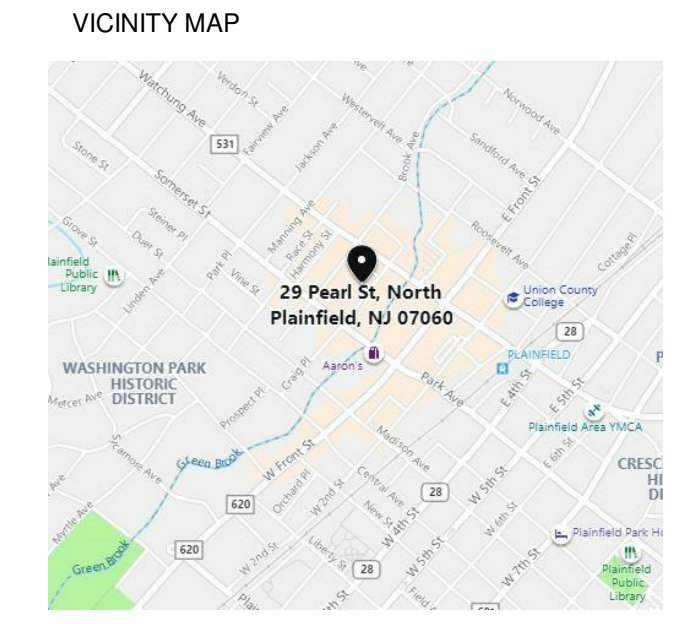

**Studio b llc**  
 144 FRESH PONDS ROAD  
 EAST BRUNSWICK, NJ 08816  
 732.713.2627

ALL DIMENSIONS MUST BE VERIFIED BY THE CONTRACTOR. NOTIFY STUDIO B ARCHITECTURE OF ANY CONFLICTS, ERRORS, AMBIGUITIES OR DISCREPANCIES IN THE CONTRACT DRAWINGS OR SPECIFICATIONS BEFORE PROCEEDING WITH CONSTRUCTION.  
 ALL DIMENSIONS SHALL BE AS NOTED IN WORDS OR NUMBERS ON THE CONTRACT DRAWINGS. DO NOT SCALE THE DRAWINGS TO DETERMINE DIMENSIONS.  
 THESE CONTRACT DRAWINGS CONTAIN DATA INTENDED SPECIFICALLY FOR THE NOTED PROJECT AND CLIENT. THEY ARE NOT INTENDED FOR USE ON EXTENSIONS OF THIS PROJECT OR FOR REUSE ON ANY OTHER PROJECT.  
 THE COPYING AND/OR MODIFICATION OF THIS DOCUMENT OR ANY PORTION THEREOF WITHOUT THE WRITTEN PERMISSION OF STUDIO B, PC, IS PROHIBITED.  
 UNLESS THESE DRAWINGS ARE SPECIFICALLY DESIGNATED AS "CONSTRUCTION ISSUE", THESE DRAWINGS SHALL NOT BE USED FOR CONSTRUCTION OR IMPROVEMENTS IDENTIFIED HEREIN. CONTRACTORS SHALL NOTIFY THE DESIGN ENGINEER TO OBTAIN CONSTRUCTION DOCUMENTS.  
 COPYRIGHT 2020 STUDIO B ARCHITECTURE - ALL RIGHTS RESERVED.

**Robert Blakeman**  
 Registered Architect - New Jersey  
 License No. 07029

SIGNATURE: DATE: 01/15/21

CLIENT  
**DR. OMOBOLA OJI**

PROJECT  
**PROPOSED 3-STORY MIXED-USE BUILDING**  
 LOT 20, BLOCK 85, 29 PEARL STREET, NORTH PLAINFIELD, NEW JERSEY

SHEET NAME  
**ADA DIAGRAMS**

JOB NO.: 2020.005  
 DATE: 11/22/20  
 DRAWN: ARCH  
 CHECK: EY / RB  
 SCALE: 1/8" = 1'-0"

SHEET NO.

**GN1.2**



1 SOUTHWEST ISOMETRIC VIEW

## SUSTAINABLE DESIGN ELEMENTS

1. INSULATION EXCEEDING STANDARD
2. 2X6 WOOD STUDS @ PERIMETER
3. WHITE REFLECTIVE ROOF
4. INSULATING GLASS
5. WATER SAVING PLUMBING FIXTURES
6. LED LIGHTING
7. LOBBIES
8. AUTOMATIC DOOR OPENERS
9. SUSTAINABLE MATERIALS

REV / ISSUE	DATE	DESCRIPTION
	01/15/21	ISSUE FOR APPROVAL

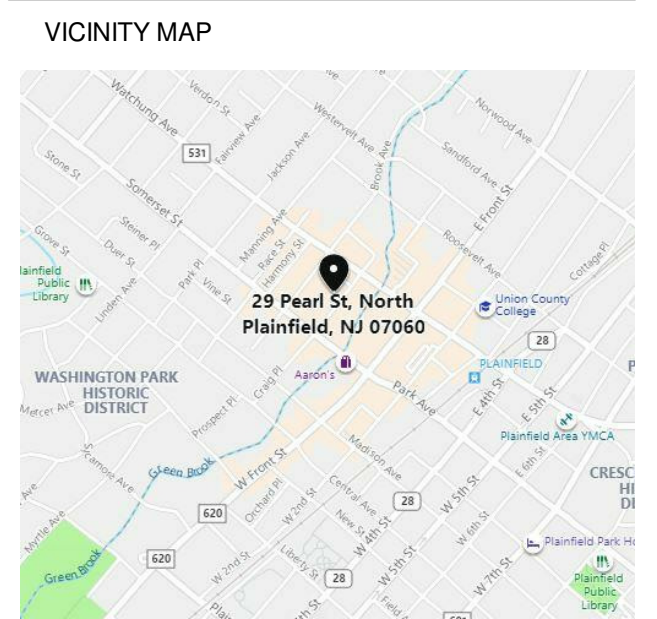

ALL DIMENSIONS MUST BE VERIFIED BY THE CONTRACTOR. NOTIFY STUDIO B ARCHITECTURE OF ANY CONFLICTS BEFORE PROCEEDING WITH CONSTRUCTION. DO NOT SCALE THE DRAWINGS TO DETERMINE DIMENSIONS.

THESE CONTRACT DRAWINGS CONTAIN DATA INTENDED SPECIFICALLY FOR THE NOTED PROJECT AND CLIENT. THEY ARE NOT INTENDED FOR USE ON OTHER PROJECTS. THE COPYING AND/OR MODIFICATION OF THIS DOCUMENT OR ANY PORTION THEREOF WITHOUT THE WRITTEN PERMISSION OF STUDIO B, PC, IS PROHIBITED.

UNLESS THESE DRAWINGS ARE SPECIFICALLY DESIGNATED AS 'CONSTRUCTION ISSUE', THESE DRAWINGS SHALL NOT BE USED FOR CONSTRUCTION OR IMPROVEMENTS DEPICTED HEREIN. CONTRACTORS SHALL NOTIFY THE DESIGN ENGINEER TO OBTAIN CONSTRUCTION DOCUMENTS.

COPYRIGHT 2020 STUDIO B ARCHITECTURE - ALL RIGHTS RESERVED.

**Robert Blakeman**  
Registered Architect - New Jersey  
Licence No. 07029

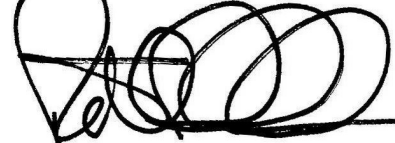
 01/15/21  
SIGNATURE DATE

CLIENT  
**DR. OMOBOLA OJI**

PROJECT  
**PROPOSED  
3-STORY  
MIXED-USE  
BUILDING**  
LOT 20, BLOCK 85, 29 PEARL STREET, NORTH  
PLAINFIELD, NEW JERSEY

SHEET NAME  
**3D VIEW**

JOB NO.: 2020.005  
DATE: 11/22/20  
DRAWN: ARCH  
CHECK: EDY / RB  
SCALE:

SHEET NO.

**GN1.3**

# BUILDING CODE INFORMATION

## SUMMARY OF ZONING & CODE DATA

The following federal, state, and municipal regulations are applicable to this Project:

North Plainfield - Borough Ordinance

New Jersey Uniform Construction Code (N.J.A.C. 5:23), incorporating with amendments the following Subcodes:

- Building Subcode: International Building Code-New Jersey Edition/2015 of the International Code Council, Inc.
- Plumbing Subcode: National Standard Plumbing Code/2015 of the National Association of Plumbing-Heating-Cooling Contractors.
- Electrical Subcode: National Electric Code (NFPA 70)/2014 of the National Fire Protection Association (NFPA).
- Fire Protection Subcode: Portions of International Building Code/2015; Portions of National Electric Code/2014; Portions of International Mechanical Code/2015; Portions of International Fuel Gas Code/2015
- Energy Subcode: International Energy Conservation Code 2015 of the International Code Council, Inc. and ASHRAE 90.1-2013 of the American Society of Heating, Refrigerating and Air-Conditioning Engineers, Inc.
- Mechanical Subcode: International Mechanical Code/2015 of the International Code Council, Inc.
- Fuel Gas Subcode: International Fuel Gas Code/2015 of the International Code Council, Inc.
- Barrier-Free Subcode: N.J.A.C. 5:23-7.1 et. seq. including technical standards of ICC/ANSI A117.1-2009

Accessibility Guidelines of the Americans with Disabilities Act (ADAAG).

## INTERNATIONAL BUILDING CODE NEW JERSEY EDITION 2018

- BUILDING CONSTRUCTION CLASSIFICATION = V-B
- USE GROUP R-2 RESIDENTIAL (2ND FLOOR & 3RD FLOOR) = PRIMARY SEPARATED USE  
B BUSINESS (1ST FLOOR) = SECONDARY SEPARATED USE  
SEPARATED MIXED USE
- MAXIMUM TRAVEL DISTANCE (SPRINKLERED BUILDING) = 250' USE GROUP R-2  
300' USE GROUP B
- ENTIRE BUILDING SHALL BE SPRINKLERED IN ACCORDANCE WITH ALL STATE AND LOCAL CODES HAVING JURISDICTION, THE LATEST NFPA 13 REQUIREMENTS
- ALL EGRESS DOORWAYS COMPLY WITH CHAPTER 10 OF INTERNATIONAL BUILDING CODE NJ 2018 EDITION
- NUMBER OF EXITS  
SPACE WITH ONE EXIT/STAIR (USE GROUP R-2), 2ND FLOOR & 3RD FLOOR  
=125' MAX TRAVEL ALLOWED (FULLY SPRINKLERED)  
=82'-0" MAX TRAVEL PROVIDED  
(USE GROUP B), 1ST FLOOR = 4 EXITS PROVIDED
- MAXIMUM OCCUPANCY CALCULATION  
USE GROUP B = FIRST FLOOR 2,791 SF / 100 = 28 MAXIMUM OCCUPANTS  
USE GROUP R2 = 2ND FLOOR 2,225 NSF / 200 = 12 MAXIMUM OCCUPANTS  
USE GROUP R2 = 3RD FLOOR 2,225 NSF / 200 = 12 MAXIMUM OCCUPANTS

# CODE DATA

## PROPOSED 3-STORY MIXED-USE BUILDING

### NEW 3-STORY MIXED-USE BUILDING

### NORTH PLAINFIELD BOROUGH ORDINANCE

22-108 ZONE B-1 BUSINESS USE

APARTMENT BUILDING WITH GROUND FLOOR OFFICE PER 22-108.1.c

LOT AREA: 9,248.32 SQ. FT.

BUILDING AREA: TOTAL = 8,689 SF

FIRST FLOOR = 2,791 SF  
SECOND FLOOR = 2,949 SF  
THIRD FLOOR = 2,949 SF

BUILDING HEIGHT: 50'-0" ALLOWED 37'-10" PROVIDED (COMPLIES)

SETBACKS: REFER TO CIVIL DRAWINGS

OFF STREET PARKING: REFER TO CIVIL DRAWINGS

ELEVATOR SERVICE REQUIRED 1 ELEVATOR PROVIDED

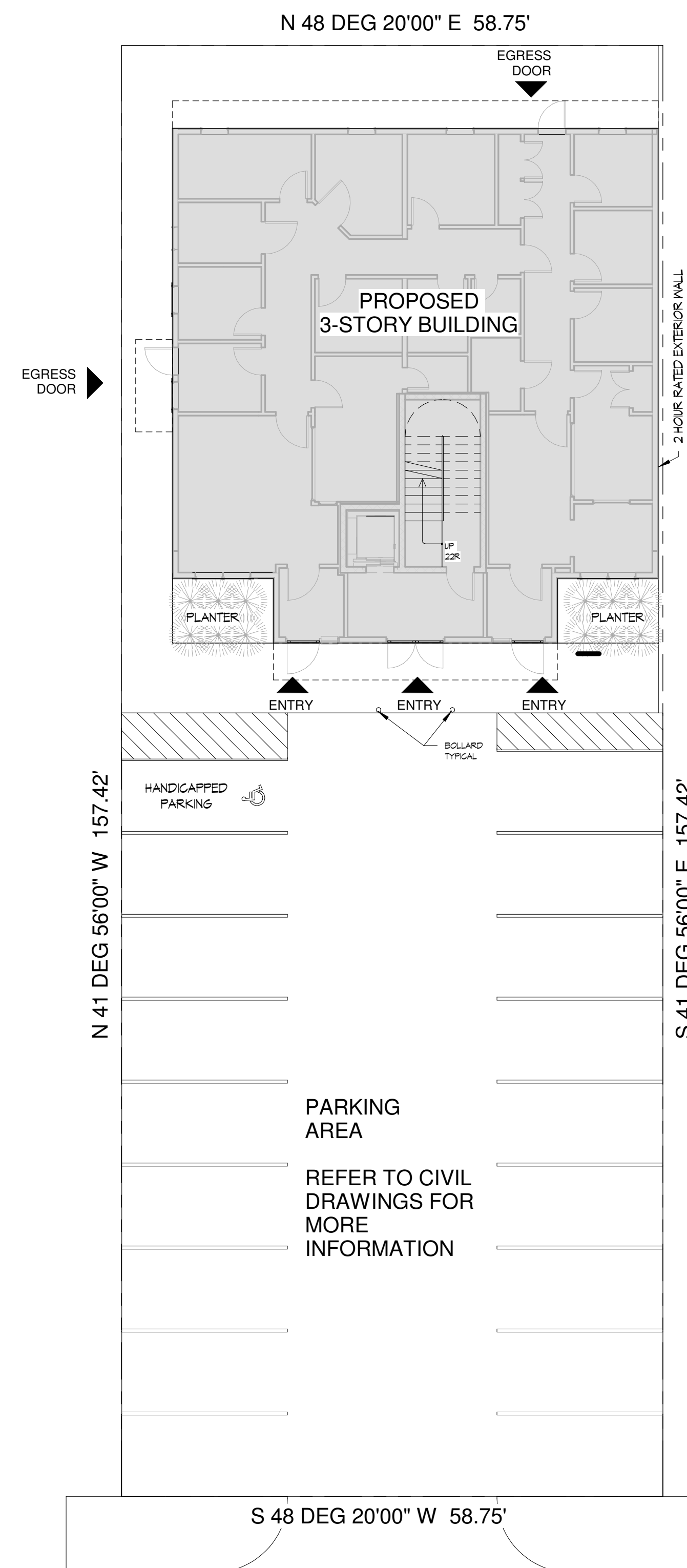

**1** ARCHITECTURAL SITE PLAN  
3/32" = 1'-0"

REV. / ISSUE	DATE	DESCRIPTION
01/15/21		ISSUE FOR APPROVAL

### VICINITY MAP

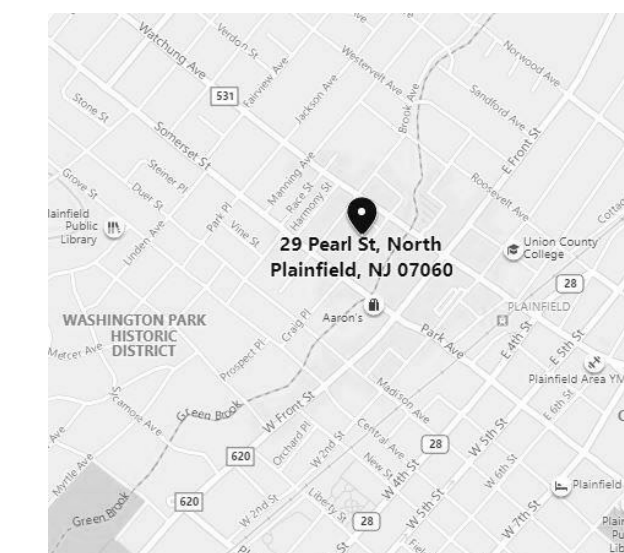

**Studio b llc**  
144 FRESH PONDS ROAD  
EAST BRUNSWICK, NJ 08816  
732.713.2627

ALL DIMENSIONS MUST BE VERIFIED BY THE CONTRACTOR. NOTIFY STUDIO B ARCHITECTURE OF ANY CONFLICTS, ERRORS, OMISSIONS OR DISCREPANCIES IN THE CONTRACT DRAWINGS OR SPECIFICATIONS BEFORE PROCEEDING WITH CONSTRUCTION.  
ALL DIMENSIONS SHALL BE AS NOTED IN WORDS OR NUMBERS ON THE CONTRACT DRAWINGS. DO NOT SCALE THE DRAWINGS TO DETERMINE DIMENSIONS.  
THESE CONTRACT DRAWINGS CONTAIN DATA INTENDED SPECIFICALLY FOR THE NOTED PROJECT AND CLIENT. THEY ARE NOT INTENDED FOR USE ON EXTENSIONS OF THIS PROJECT OR FOR REUSE ON ANY OTHER PROJECT.  
THE COPYING AND/OR MODIFICATION OF THIS DOCUMENT OR ANY PORTION THEREOF WITHOUT THE WRITTEN PERMISSION OF STUDIO B, PC, IS PROHIBITED.  
UNLESS THESE DRAWINGS ARE SPECIFICALLY DESIGNATED AS "CONSTRUCTION ISSUE", THESE DRAWINGS SHALL NOT BE USED FOR CONSTRUCTION OR IMPROVEMENTS IDENTIFIED HEREIN. CONTRACTORS SHALL NOTIFY THE DESIGN ENGINEER TO OBTAIN CONSTRUCTION DOCUMENTS.  
COPYRIGHT 2020 STUDIO B ARCHITECTURE - ALL RIGHTS RESERVED.

**Robert Blakeman**  
Registered Architect - New Jersey  
Licence No. 07029

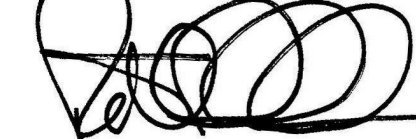
  
SIGNATURE DATE 01/15/21

CLIENT  
**DR. OMOBOLA OJI**

PROJECT  
**PROPOSED 3-STORY MIXED-USE BUILDING**  
LOT 20, BLOCK 85, 29 PEARL STREET, NORTH PLAINFIELD, NEW JERSEY

SHEET NAME  
**ARCHITECTURAL SITE PLAN**

JOB NO.: 2020.005  
DATE: 11/22/20  
DRAWN: ARCH  
CHECK: EY / RB  
SCALE: As indicated

SHEET NO.

**A0.01**

REV / ISSUE	DATE	DESCRIPTION
01/15/21		ISSUE FOR APPROVAL

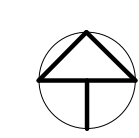
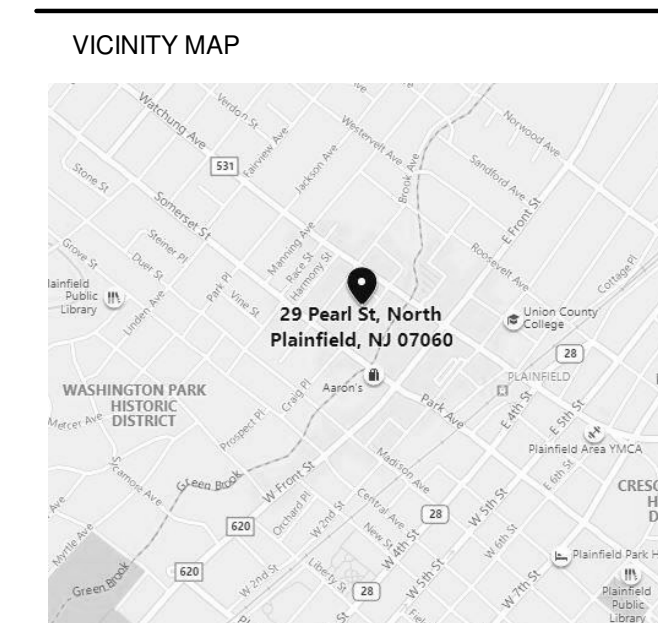

**Studio b llc**  
 144 FRESH PONDS ROAD  
 EAST BRUNSWICK, NJ 08816  
 732.713.2627

ALL DIMENSIONS MUST BE VERIFIED BY THE CONTRACTOR. NOTIFY STUDIO B ARCHITECTURE OF ANY CONFLICTS, ERRORS, OMISSIONS OR DISCREPANCIES IN THE CONTRACT DRAWINGS OR SPECIFICATIONS BEFORE PROCEEDING WITH CONSTRUCTION. DO NOT SCALE THE DRAWINGS TO DETERMINE DIMENSIONS.  
 THESE CONTRACT DRAWINGS CONTAIN DATA INTENDED SPECIFICALLY FOR THE NOTED PROJECT AND CLIENT. THEY ARE NOT INTENDED FOR USE ON EXTENSIONS OF THIS PROJECT OR FOR ANY OTHER PROJECT.  
 THE COPYING AND/OR MODIFICATION OF THIS DOCUMENT OR ANY PORTION THEREOF WITHOUT THE WRITTEN PERMISSION OF STUDIO B, PC, IS PROHIBITED.  
 UNLESS THESE DRAWINGS ARE SPECIFICALLY DESIGNATED AS "CONSTRUCTION ISSUE", THESE DRAWINGS SHALL NOT BE USED FOR CONSTRUCTION OR IMPROVEMENTS DEPICTED HEREIN. CONTRACTORS SHALL NOTIFY THE DESIGN ENGINEER TO OBTAIN CONSTRUCTION DOCUMENTS.  
 COPYRIGHT 2020 STUDIO B ARCHITECTURE - ALL RIGHTS RESERVED.

**Robert Blakeman**  
 Registered Architect - New Jersey  
 License No. 07029

*[Signature]* 01/15/21  
 SIGNATURE DATE

CLIENT  
**DR. OMOBOLA OJI**

PROJECT  
**PROPOSED 3-STORY MIXED-USE BUILDING**  
 LOT 20, BLOCK 85, 29 PEARL STREET, NORTH PLAINFIELD, NEW JERSEY

SHEET NAME  
**FIRST FLOOR PLAN**

JOB NO.: 2020.005  
 DATE: 11/22/20  
 DRAWN: ARCH  
 CHECK: EY / RB  
 SCALE: 1/4" = 1'-0"

SHEET NO.

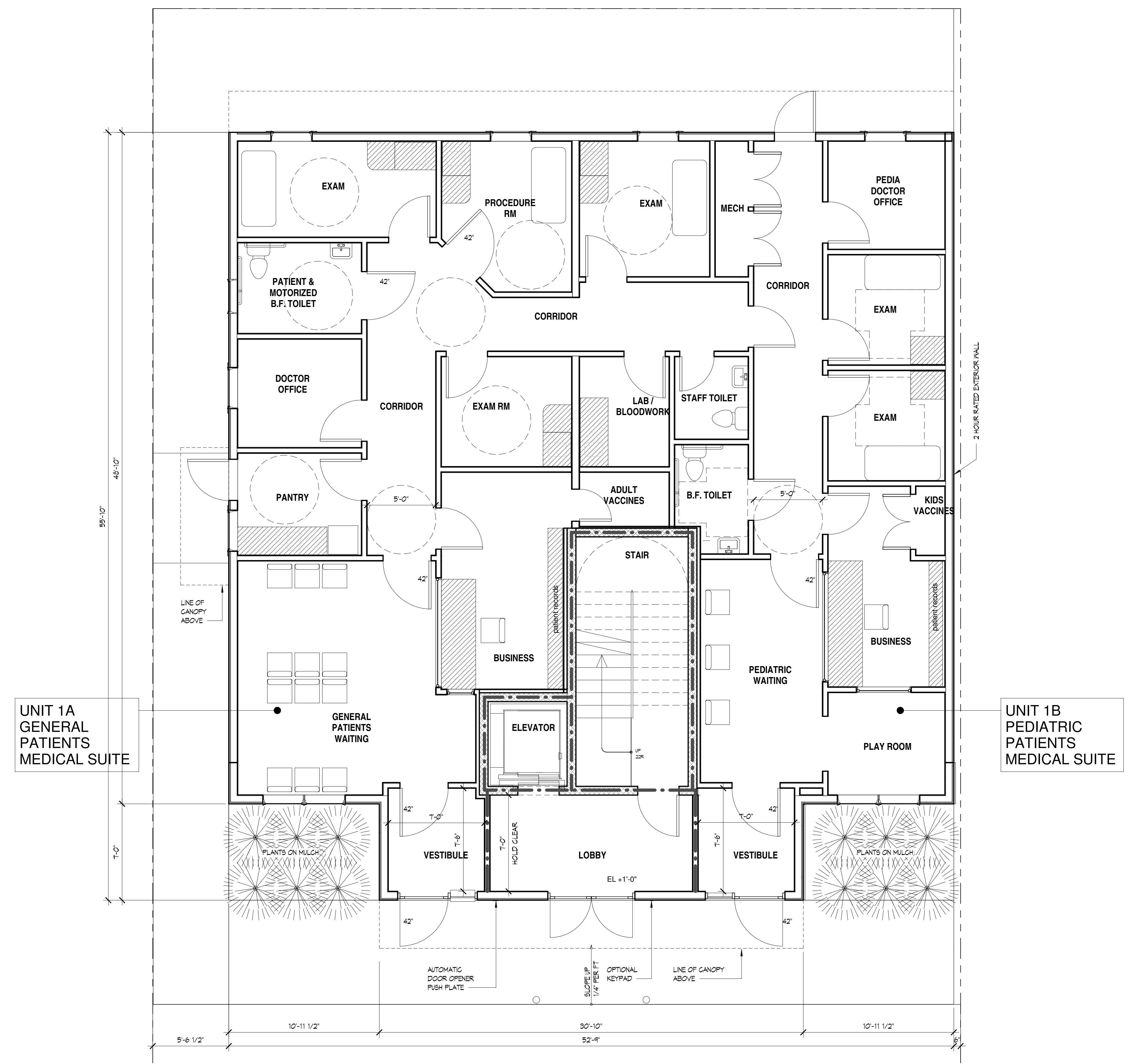

**1 FIRST FLOOR PLAN**  
 1/4" = 1'-0"

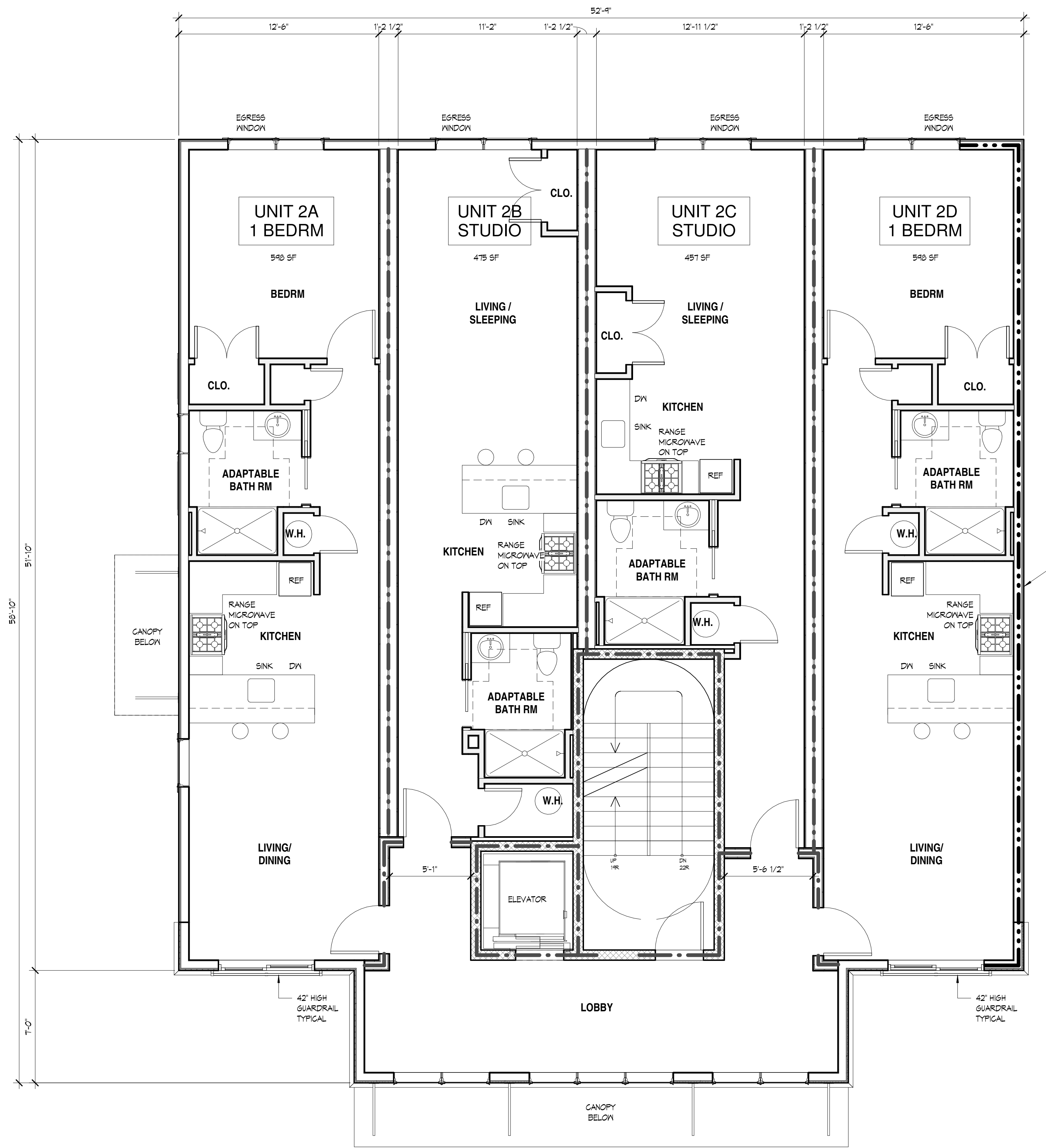

**1 SECOND FLOOR PLAN**  
1/4" = 1'-0"

**GENERAL NOTES:**

**2 HOUR RATED FIREWALL CONSTRUCTION (WEST EXTERIOR WALL ONLY) PER U.L. DESIGN NO. M408**

2 LAYERS TYPE-X GYPSUM BOARD, (INTERIOR SIDE)  
2X6 WOOD STUDS  
R-21 (TOTAL) INSULATION  
2 LAYERS TYPE-X GYPSUM BOARD (EXTERIOR)  
AIR/WATER BARRIER  
HARDIE PLANKS SIDING EXTERIOR FINISH

**NON-RATED EXTERIOR WALL**

1 LAYER 5/8" THK GYPSUM BOARD, (INTERIOR SIDE)  
2X6 WOOD STUDS  
R-21 (TOTAL) INSULATION  
1 LAYER EXTERIOR SHEATHING (EXTERIOR)  
AIR/WATER BARRIER  
HARDIE PLANKS SIDING EXTERIOR FINISH (NORTH/WEST WALLS)  
THIN BRICK VENEER SYSTEM (SOUTH WALL - 1ST FLOOR)  
E.I.F.S. WALL SYSTEM (SOUTH WALL - 2ND/3RD FLOORS)

**1 HOUR RATED UNIT DEMISING PARTITION**

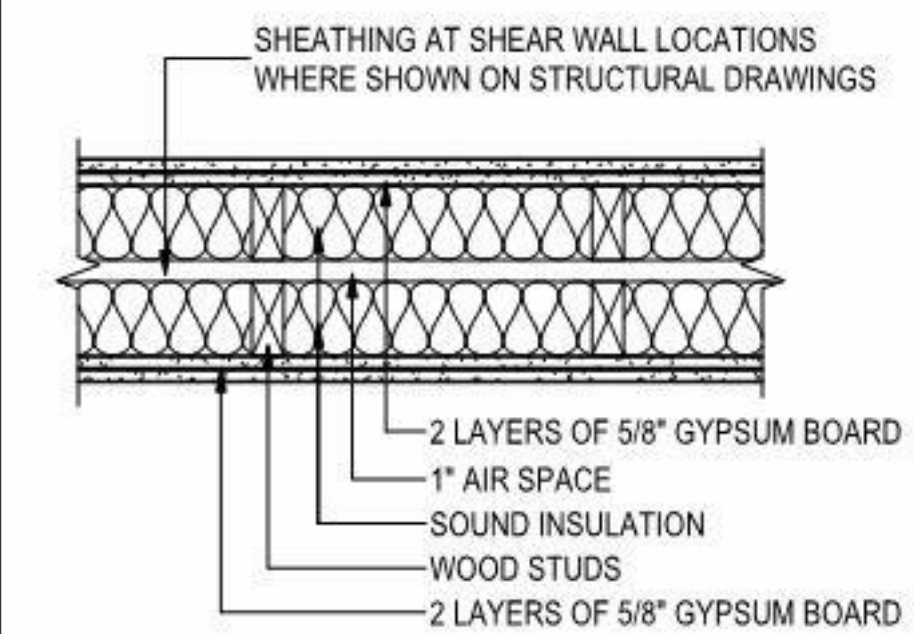

**1 HOUR RATED WALL**  
UL DESIGN - U341  
STC 63 MIN.

**1 HOUR RATED CORRIDOR WALL**

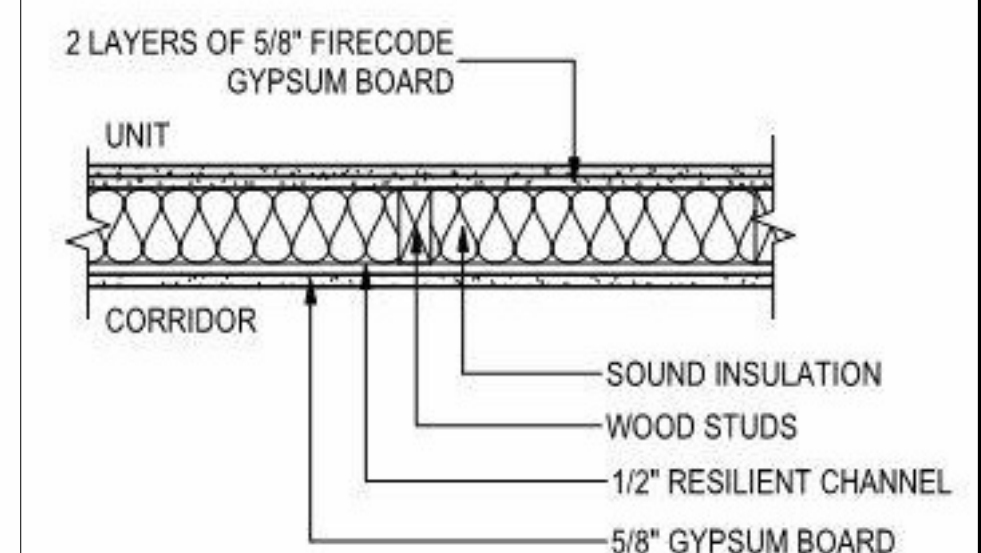

**1 HOUR RATED WALL**  
UL DESIGN U311  
STC 50 - 54

REV / ISSUE	DATE	DESCRIPTION
01/15/21		ISSUE FOR APPROVAL

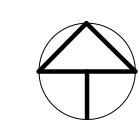
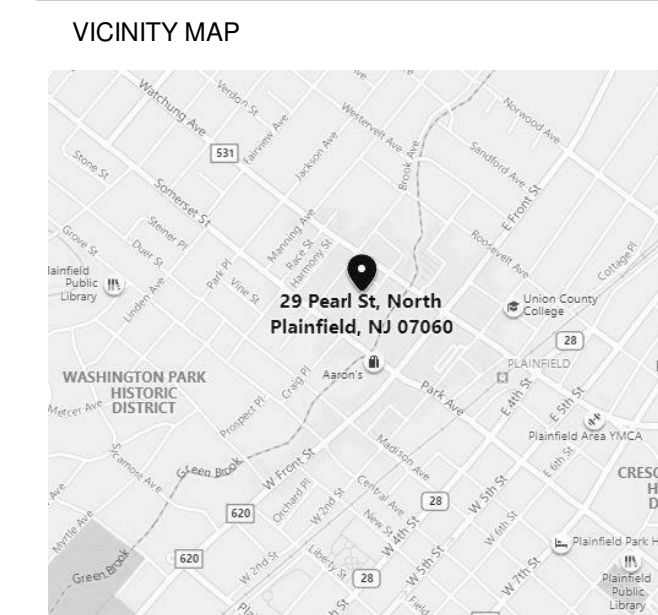

**Studio b llc**  
144 FRESH PONDS ROAD  
EAST BRUNSWICK, NJ 08816  
732.713.2627

ALL DIMENSIONS MUST BE VERIFIED BY THE CONTRACTOR. NOTIFY STUDIO B ARCHITECTURE OF ANY CONFLICTS BEFORE PROCEEDING WITH CONSTRUCTION. DO NOT SCALE THE DRAWINGS TO DETERMINE DIMENSIONS. THESE CONTRACT DRAWINGS CONTAIN DATA INTENDED SPECIFICALLY FOR THE NOTED PROJECT AND CLIENT. THEY ARE NOT INTENDED FOR USE ON OTHER PROJECTS. THE COPYING AND/OR MODIFICATION OF THIS DOCUMENT OR ANY PORTION THEREOF WITHOUT THE WRITTEN PERMISSION OF STUDIO B, PC, IS PROHIBITED. UNLESS THESE DRAWINGS ARE SPECIFICALLY DESIGNATED AS 'CONSTRUCTION ISSUE', THESE DRAWINGS SHALL NOT BE USED FOR CONSTRUCTION OR IMPROVEMENTS. CONTRACTORS SHALL NOTIFY THE DESIGN ENGINEER TO OBTAIN CONSTRUCTION DOCUMENTS. COPYRIGHT 2020 STUDIO B ARCHITECTURE - ALL RIGHTS RESERVED.

**Robert Blakeman**  
Registered Architect - New Jersey  
Licence No. 07029

*[Signature]* 01/15/21  
SIGNATURE DATE

CLIENT  
**DR. OMOBOLA OJI**

PROJECT  
**PROPOSED 3-STORY MIXED-USE BUILDING**  
LOT 20, BLOCK 85, 29 PEARL STREET, NORTH PLAINFIELD, NEW JERSEY

SHEET NAME  
**SECOND FLOOR PLAN**

JOB NO.: 2020.005  
DATE: 11/22/20  
DRAWN: ARCH  
CHECK: EY / RB  
SCALE: 1/4" = 1'-0"

SHEET NO.

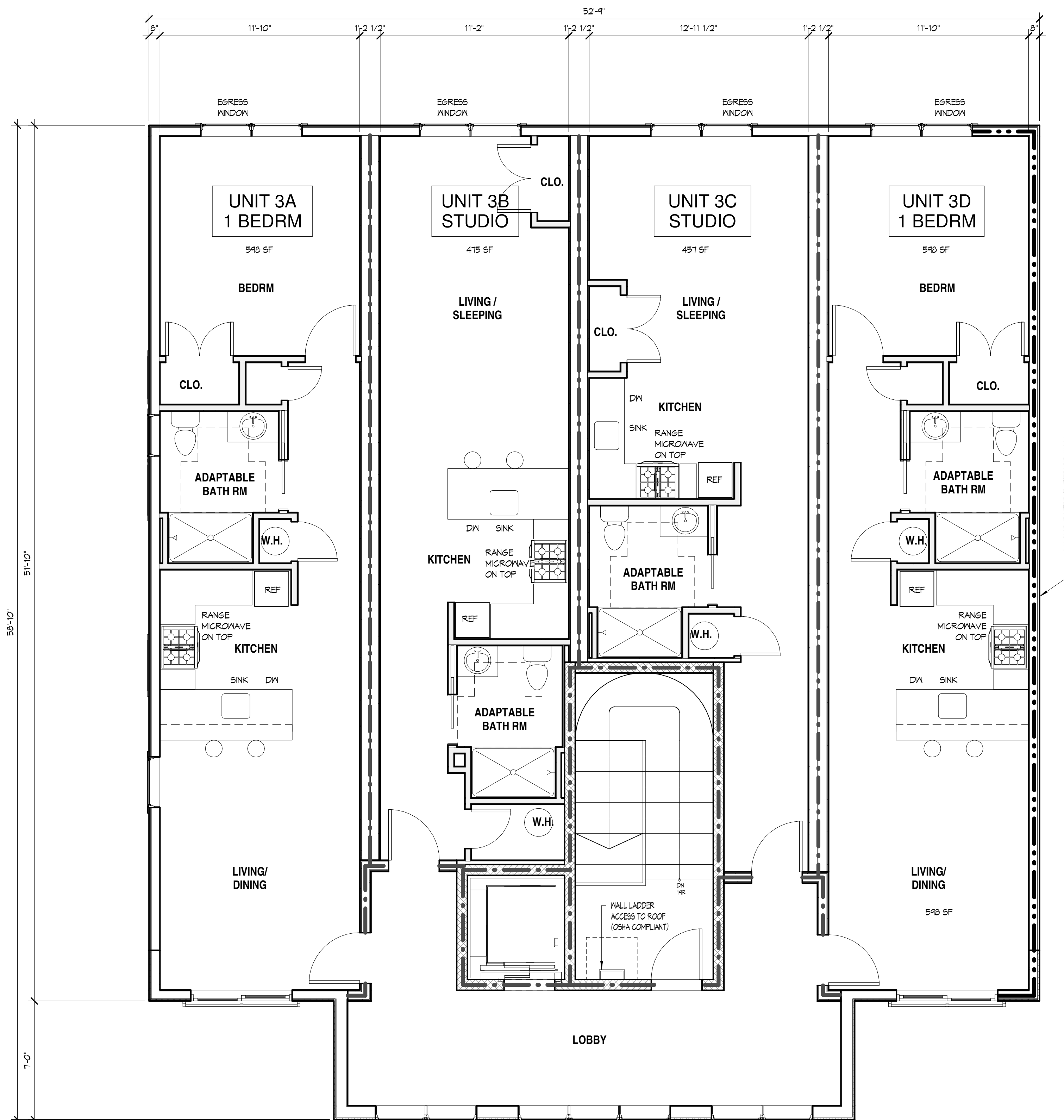

**1** THIRD FLOOR CONSTRUCTION PLAN  
1/4" = 1'-0"

REV. / ISSUE	DATE	DESCRIPTION
01/15/21		ISSUE FOR APPROVAL

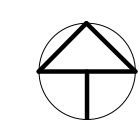
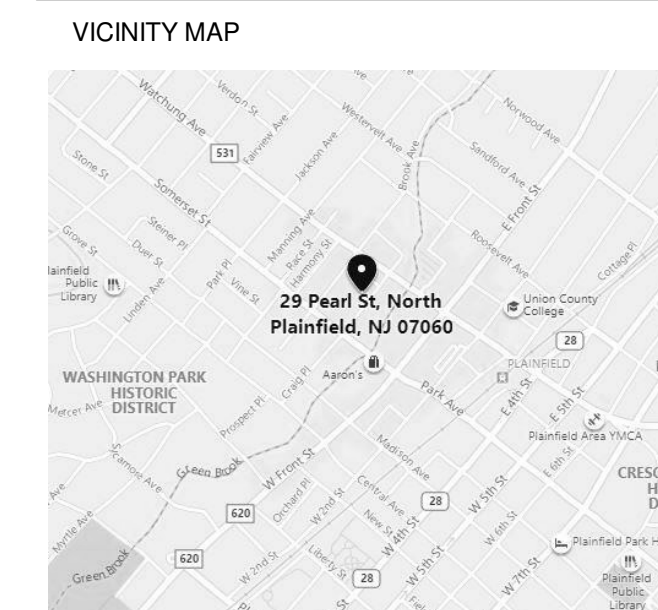

**Studio b llc**  
144 FRESH PONDS ROAD  
EAST BRUNSWICK, NJ 08816  
732.713.2627

ALL DIMENSIONS MUST BE VERIFIED BY THE CONTRACTOR. NOTIFY STUDIO B ARCHITECTURE OF ANY CONFLICTS, ERRORS, OMISSIONS OR DISCREPANCIES IN THE CONTRACT DRAWINGS OR SPECIFICATIONS BEFORE PROCEEDING WITH CONSTRUCTION.  
ALL DIMENSIONS SHALL BE AS NOTED IN WORDS OR NUMBERS ON THE CONTRACT DRAWINGS. DO NOT SCALE THE DRAWINGS TO DETERMINE DIMENSIONS.  
THESE CONTRACT DRAWINGS CONTAIN DATA INTENDED SPECIFICALLY FOR THE NOTED PROJECT AND CLIENT. THEY ARE NOT INTENDED FOR USE ON EXTENSIONS OF THIS PROJECT OR FOR REUSE ON ANY OTHER PROJECT.  
THE COPYING AND/OR MODIFICATION OF THIS DOCUMENT OR ANY PORTION THEREOF WITHOUT THE WRITTEN PERMISSION OF STUDIO B, PC, IS PROHIBITED.  
UNLESS THESE DRAWINGS ARE SPECIFICALLY DESIGNATED AS "CONSTRUCTION ISSUE", THESE DRAWINGS SHALL NOT BE USED FOR CONSTRUCTION OR IMPROVEMENTS DEPICED HEREIN. CONTRACTORS SHALL NOTIFY THE DESIGN ENGINEER TO OBTAIN CONSTRUCTION DOCUMENTS.  
COPYRIGHT 2020 STUDIO B ARCHITECTURE - ALL RIGHTS RESERVED.

**Robert Blakeman**  
Registered Architect - New Jersey  
Licence No. 07029

*[Signature]* 01/15/21  
SIGNATURE DATE

CLIENT  
**DR. OMOBOLA OJI**

PROJECT  
**PROPOSED  
3-STORY  
MIXED-USE  
BUILDING**  
LOT 20, BLOCK 85, 29 PEARL STREET, NORTH  
PLAINFIELD, NEW JERSEY

SHEET NAME  
**THIRD FLOOR PLAN**

JOB NO.: 2020.005  
DATE: 11/22/20  
DRAWN: ARCH  
CHECK: EY / RB  
SCALE: 1/4" = 1'-0"

SHEET NO.



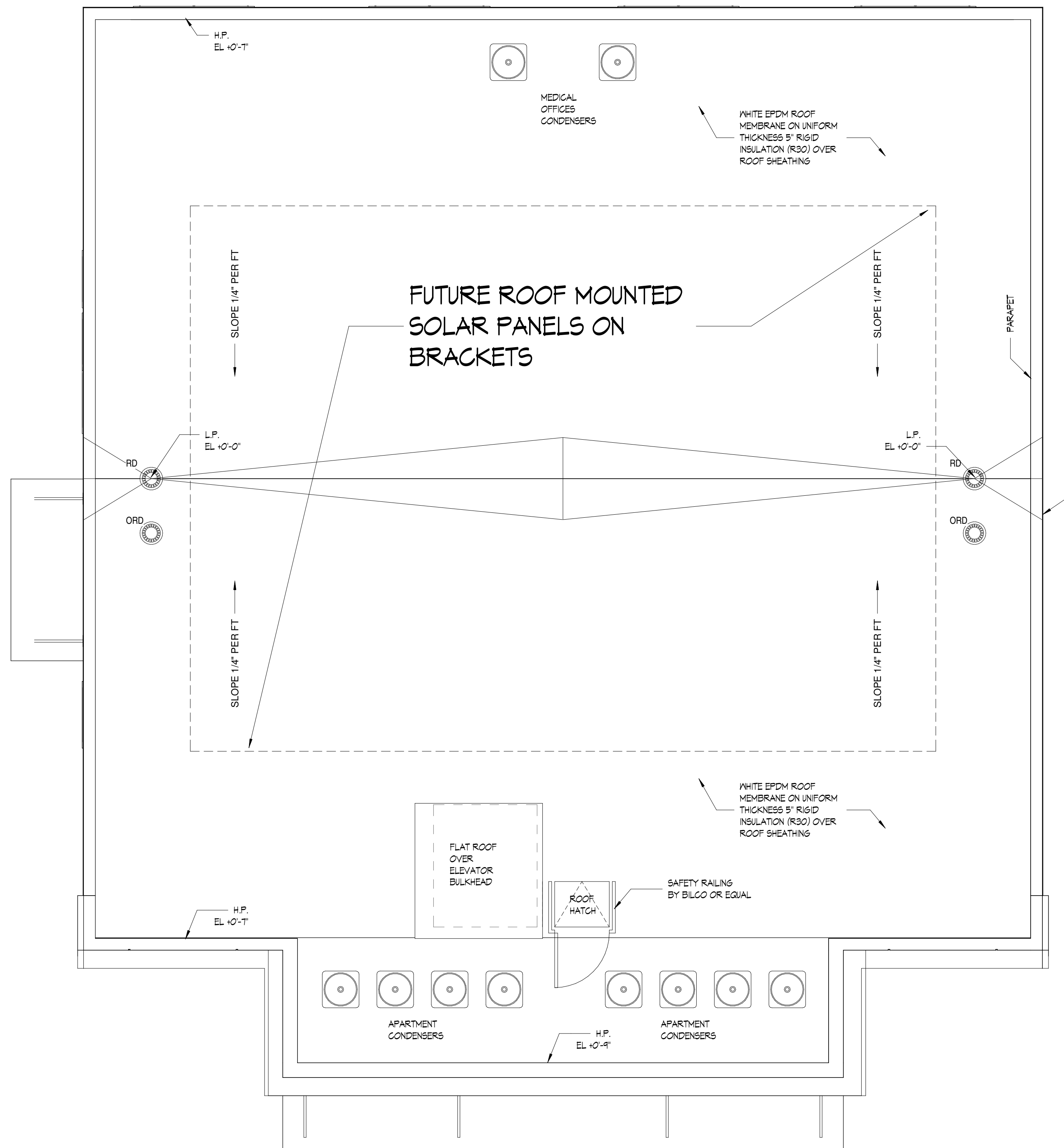

**1** ROOF PLAN  
1/4" = 1'-0"

REV / ISSUE	DATE	DESCRIPTION
	01/15/21	ISSUE FOR APPROVAL

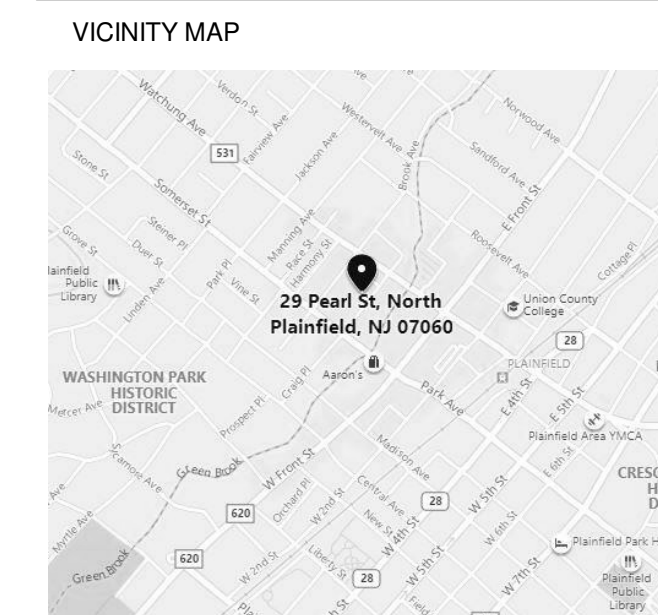

**Studio b llc**  
 144 FRESH PONDS ROAD  
 EAST BRUNSWICK, NJ 08816  
 732.713.2627

ALL DIMENSIONS MUST BE VERIFIED BY THE CONTRACTOR. NOTIFY STUDIO B ARCHITECTURE OF ANY CONFLICTS, ERRORS, AMBIGUITIES OR DISCREPANCIES IN THE CONTRACT DRAWINGS OR SPECIFICATIONS BEFORE PROCEEDING WITH CONSTRUCTION.  
 ALL DIMENSIONS SHALL BE AS NOTED IN WORDS OR NUMBERS ON THE CONTRACT DRAWINGS. DO NOT SCALE THE DRAWINGS TO DETERMINE DIMENSIONS.  
 THESE CONTRACT DRAWINGS CONTAIN DATA INTENDED SPECIFICALLY FOR THE NOTED PROJECT AND CLIENT. THEY ARE NOT INTENDED FOR USE ON EXTENSIONS OF THIS PROJECT OR FOR REUSE ON ANY OTHER PROJECT.  
 THE COPYING AND/OR MODIFICATION OF THIS DOCUMENT OR ANY PORTION THEREOF WITHOUT THE WRITTEN PERMISSION OF STUDIO B, PC, IS PROHIBITED.  
 UNLESS THESE DRAWINGS ARE SPECIFICALLY DESIGNATED AS "CONSTRUCTION ISSUE", THESE DRAWINGS SHALL NOT BE USED FOR CONSTRUCTION OR IMPROVEMENTS DEPICTED HEREIN. CONTRACTORS SHALL NOTIFY THE DESIGN ENGINEER TO OBTAIN CONSTRUCTION DOCUMENTS.  
 COPYRIGHT 2020 STUDIO B ARCHITECTURE - ALL RIGHTS RESERVED.

**Robert Blakeman**  
 Registered Architect - New Jersey  
 License No. 07029

*[Signature]* 01/15/21  
 SIGNATURE DATE

CLIENT  
**DR. OMOBOLA OJI**

PROJECT  
**PROPOSED  
 3-STORY  
 MIXED-USE  
 BUILDING**  
 LOT 20, BLOCK 85, 29 PEARL STREET, NORTH  
 PLAINFIELD, NEW JERSEY

SHEET NAME  
**ROOF PLAN**

JOB NO.: 2020.005  
 DATE: 11/22/20  
 DRAWN: ARCH  
 CHECK: EY / RB  
 SCALE: 1/4" = 1'-0"

SHEET NO.

REV / ISSUE	DATE	DESCRIPTION
01/15/21		ISSUE FOR APPROVAL

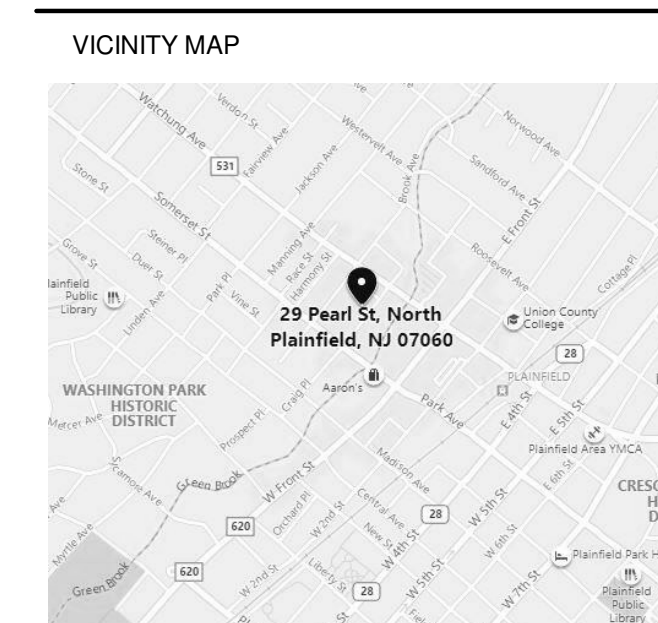

**Studio b llc**  
 144 FRESH PONDS ROAD  
 EAST BRUNSWICK, NJ 08816  
 732.713.2627

ALL DIMENSIONS MUST BE VERIFIED BY THE CONTRACTOR. NOTIFY STUDIO B ARCHITECTURE OF ANY CONFLICTS, ERRORS, OMISSIONS OR DISCREPANCIES IN THE CONTRACT DRAWINGS OR SPECIFICATIONS BEFORE PROCEEDING WITH CONSTRUCTION.  
 ALL DIMENSIONS SHALL BE AS NOTED IN WORDS OR NUMBERS ON THE CONTRACT DRAWINGS. DO NOT SCALE THE DRAWINGS TO DETERMINE DIMENSIONS.  
 THESE CONTRACT DRAWINGS CONTAIN DATA INTENDED SPECIFICALLY FOR THE NOTED PROJECT AND CLIENT. THEY ARE NOT INTENDED FOR USE ON EXTENSIONS OF THIS PROJECT OR FOR REUSE ON ANY OTHER PROJECT.  
 THE COPYING AND/OR MODIFICATION OF THIS DOCUMENT OR ANY PORTION THEREOF WITHOUT THE WRITTEN PERMISSION OF STUDIO B, PC, IS PROHIBITED.  
 UNLESS THESE DRAWINGS ARE SPECIFICALLY DESIGNATED AS "CONSTRUCTION ISSUE", THESE DRAWINGS SHALL NOT BE USED FOR CONSTRUCTION OR IMPROVEMENTS. DENYED HEREIN, CONTRACTORS SHALL NOTIFY THE DESIGN ENGINEER TO OBTAIN CONSTRUCTION DOCUMENTS.  
 COPYRIGHT 2020 STUDIO B ARCHITECTURE - ALL RIGHTS RESERVED.

**Robert Blakeman**  
 Registered Architect - New Jersey  
 License No. 07029

*[Signature]*  
 SIGNATURE DATE 01/15/21

CLIENT  
**DR. OMOBOLA OJI**

PROJECT  
**PROPOSED  
 3-STORY  
 MIXED-USE  
 BUILDING**  
 LOT 20, BLOCK 85, 29 PEARL STREET, NORTH  
 PLAINFIELD, NEW JERSEY

SHEET NAME  
**NORTH & SOUTH  
 ELEVATIONS**

JOB NO.: 2020.005  
 DATE: 11/22/20  
 DRAWN: ARCH  
 CHECK: EY / RB  
 SCALE: 3/16" = 1'-0"

SHEET NO.

**A2.01**

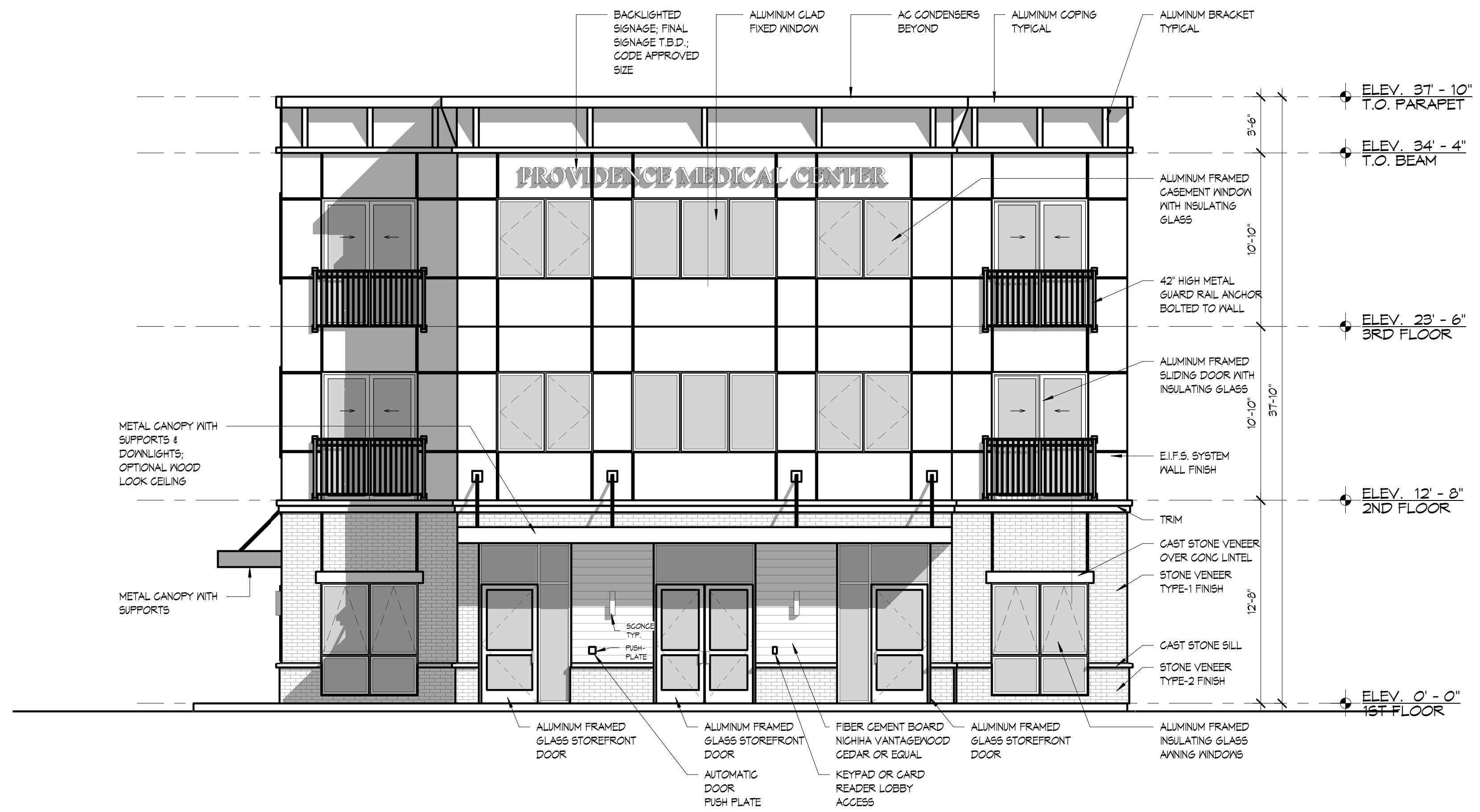

**1 SOUTH ELEVATION**  
 3/16" = 1'-0"

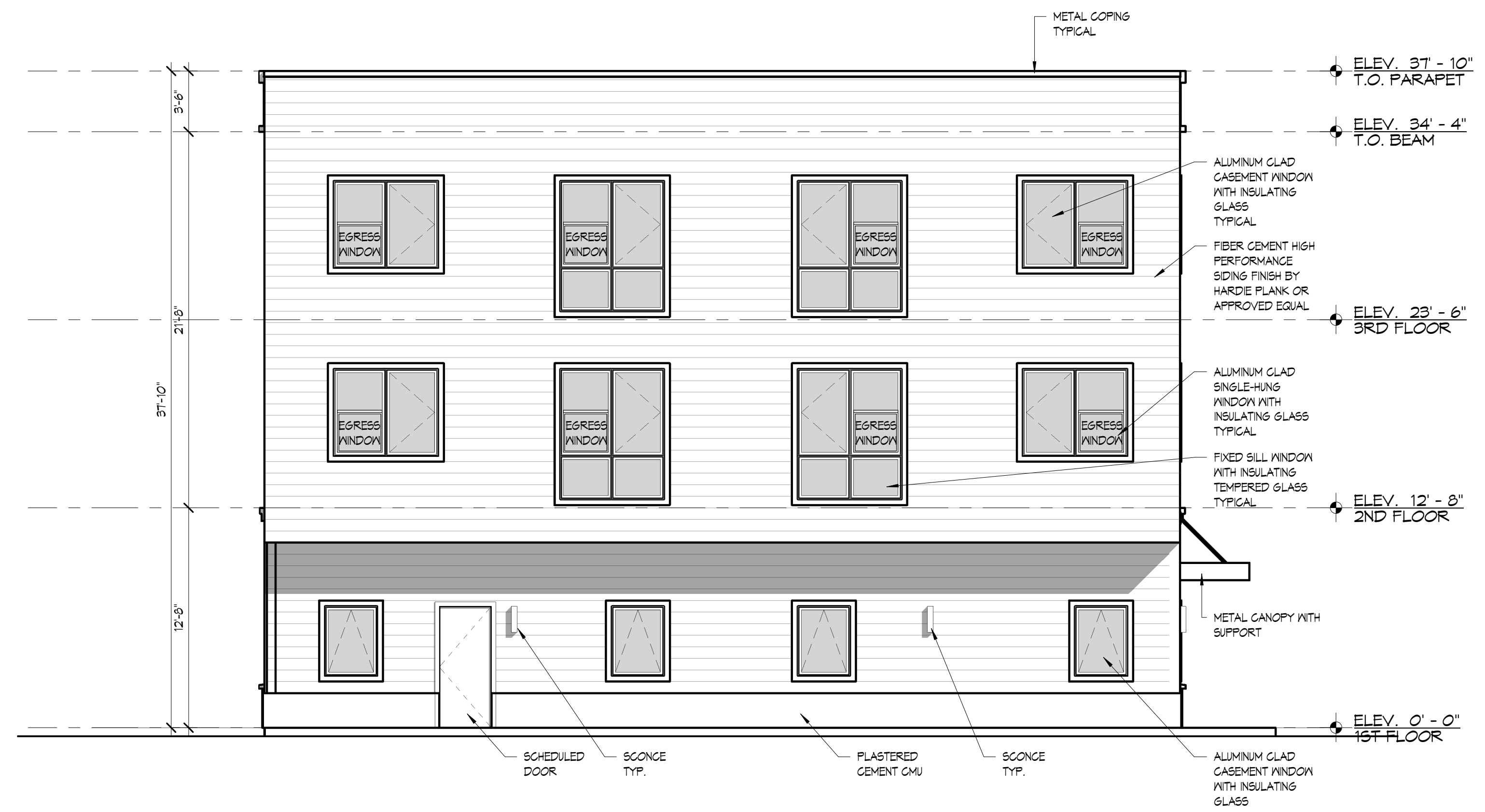

**2 NORTH ELEVATION**  
 3/16" = 1'-0"

**GENERAL NOTES:**

1. PROVIDE WINDOW FRAMES IN BLACK COLOR, ENTIRE BUILDING.
2. PROVIDE ALL STOREFRONTS, DOOR FRAMES, & SIDELITES FRAMES IN BLACK COLOR.
3. PROVIDE PUSH PLATES AUTOMATIC DOOR OPENER TO UNIT 1A MEDICAL OFFICE VESTIBULE. PUSH PLATE WILL OPEN BOTH 2 VESTIBULE DOORS SIMULTANEOUSLY. PROVIDE PUSH PLATE AT EXTERIOR AND INTERIOR SIDE.
4. EGRESS/RESCUE WINDOW SHALL BE CODE COMPLIANT IN SIZE.
5. STONE VENEER TYPE-1 FINISH SHALL BE TABS II THIN BRICK WALL SYSTEM, BRICK COLOR TYPE 1  
 WEBSITE: TABSWALLSYSTEMS.COM  
 TEL NO. 616-954-5400
6. STONE VENEER TYPE-2 FINISH SHALL BE TABS II THIN BRICK WALL SYSTEM, BRICK COLOR TYPE 2  
 WEBSITE: TABSWALLSYSTEMS.COM  
 TEL NO. 616-954-5400

REV / ISSUE	DATE	DESCRIPTION
01/15/21		ISSUE FOR APPROVAL

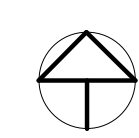
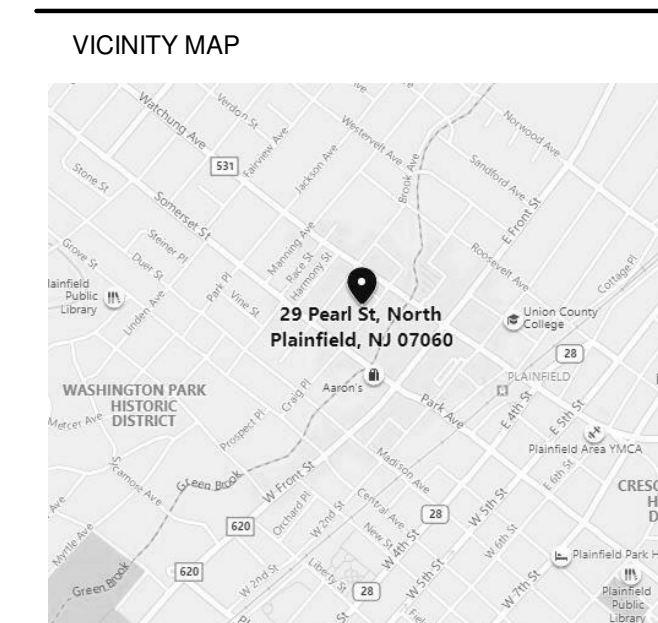

**Studio b llc**  
 144 FRESH PONDS ROAD  
 EAST BRUNSWICK, NJ 08816  
 732.713.2627

ALL DIMENSIONS MUST BE VERIFIED BY THE CONTRACTOR. NOTIFY STUDIO B ARCHITECTURE OF ANY CONFLICTS, ERRORS, OMISSIONS OR DISCREPANCIES IN THE CONTRACT DRAWINGS OR SPECIFICATIONS BEFORE PROCEEDING WITH CONSTRUCTION.  
 ALL DIMENSIONS SHALL BE AS NOTED IN WORDS OR NUMBERS ON THE CONTRACT DRAWINGS. DO NOT SCALE THE DRAWINGS TO DETERMINE DIMENSIONS.  
 THESE CONTRACT DRAWINGS CONTAIN DATA INTENDED SPECIFICALLY FOR THE NOTED PROJECT AND CLIENT. THEY ARE NOT INTENDED FOR USE ON EXTENSIONS OF THIS PROJECT OR FOR OTHER PROJECTS.  
 THE COPYING AND/OR MODIFICATION OF THIS DOCUMENT OR ANY PORTION THEREOF WITHOUT THE WRITTEN PERMISSION OF STUDIO B, P.C. IS PROHIBITED.  
 UNLESS THESE DRAWINGS ARE SPECIFICALLY DESIGNATED AS "CONSTRUCTION ISSUE", THESE DRAWINGS SHALL NOT BE USED FOR CONSTRUCTION OR IMPROVEMENTS DEPICTED HEREIN. CONTRACTORS SHALL NOTIFY THE DESIGN ENGINEER TO OBTAIN CONSTRUCTION DOCUMENTS.  
 COPYRIGHT 2020 STUDIO B ARCHITECTURE. ALL RIGHTS RESERVED.

**Robert Blakeman**  
 Registered Architect - New Jersey  
 License No. 07029

*[Signature]* 01/15/21  
 SIGNATURE DATE

CLIENT  
**DR. OMOBOLA OJI**

PROJECT  
**PROPOSED  
 3-STORY  
 MIXED-USE  
 BUILDING**  
 LOT 20, BLOCK 85, 29 PEARL STREET, NORTH  
 PLAINFIELD, NEW JERSEY

SHEET NAME  
**EAST & WEST ELEVATIONS**

JOB NO.: 2020.005  
 DATE: 11/22/20  
 DRAWN: ARCH  
 CHECK: EY / RB  
 SCALE: 3/16" = 1'-0"

SHEET NO.

**A2.02**

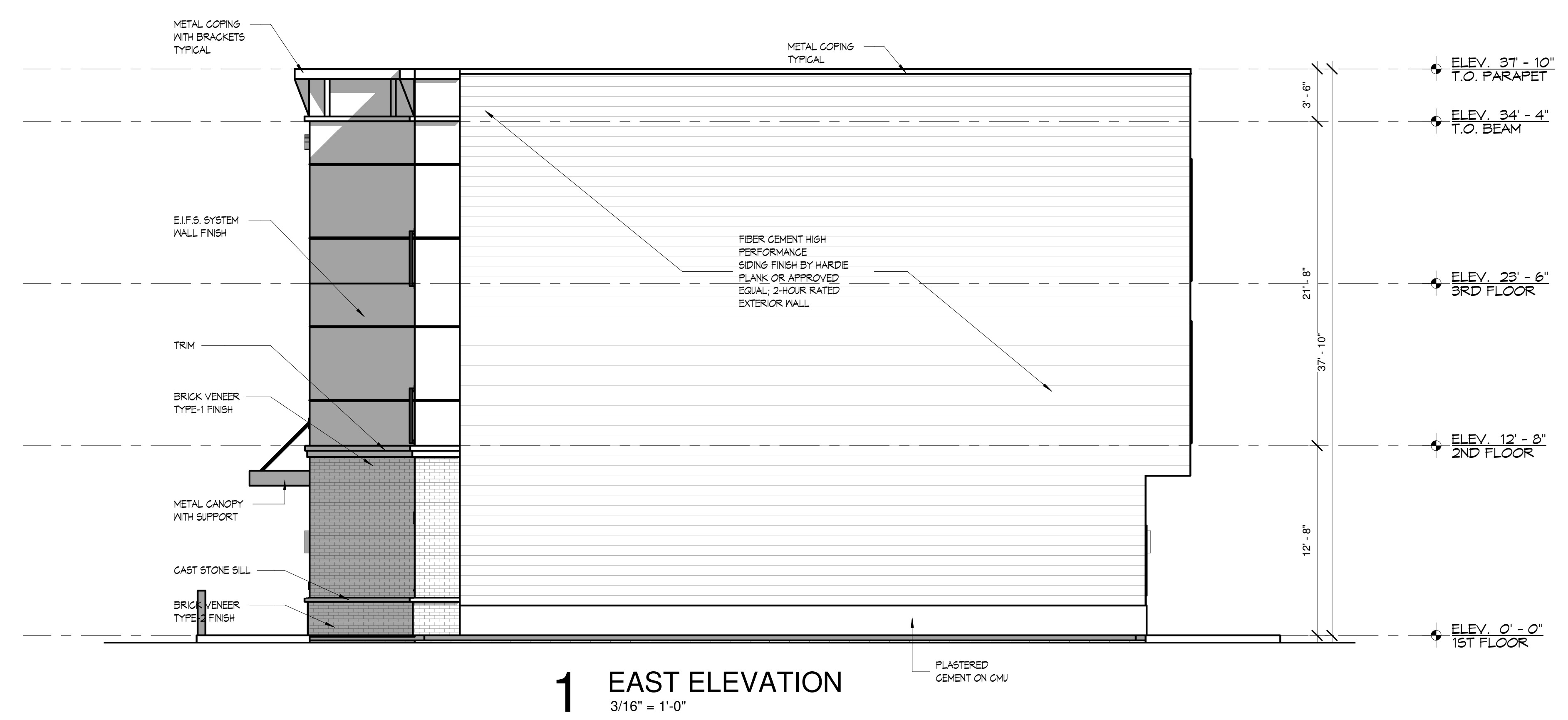

**1 EAST ELEVATION**  
 3/16" = 1'-0"

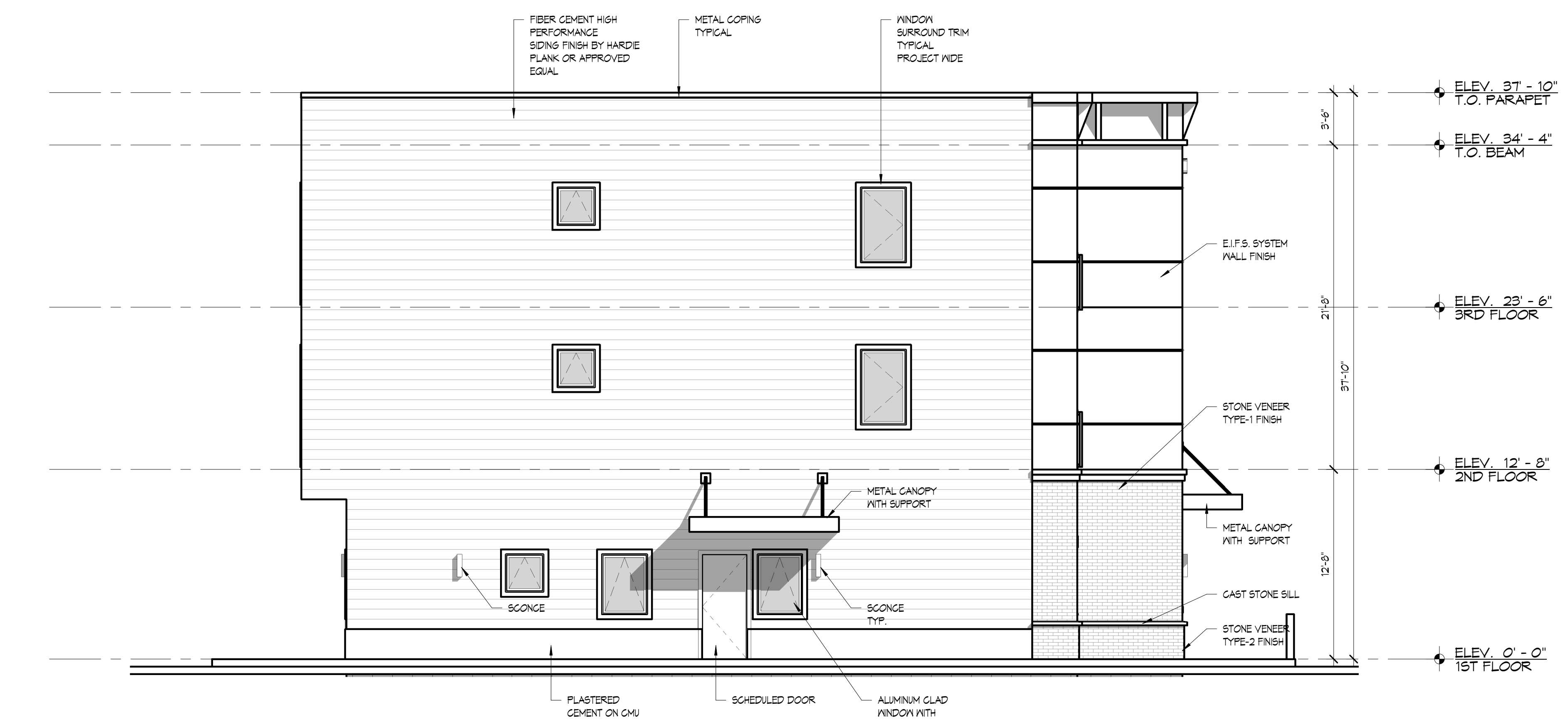

**2 WEST ELEVATION**  
 3/16" = 1'-0"